

Colorado 4-H Horse Show Rule Book

LA1500K
2024



COLORADO STATE UNIVERSITY
EXTENSION

ACKNOWLEDGMENTS

The following members of the Colorado 4-H State Horse Advisory Rules Subcommittee assisted in the revision of the current Colorado 4-H Horse Show Rulebook:

Mercedes Glenn (Douglas)
Angela Mannick (Elbert)
Jodie Martin-Witt (Larimer)
Tiffany Mead (Jefferson)
Carmen Porter (Boulder)
Tom Sharpe (Mesa)
Jonathan Vrabc (El Paso)
Lindsay Wadhams (Colorado State Fair)

PERMISSION TO REPRODUCE PUBLICATION

Requests for permission to reproduce any parts or all of this Colorado 4-H Youth-Development publication should be directed to:

4-H Publications Liaison
State 4-H Office
Colorado State University
Cooperative Extension
4040 Campus Delivery
Fort Collins, CO 80523-4040

Colorado State University Extension is an equal opportunity provider. Colorado State University does not discriminate on the basis of disability and is committed to providing reasonable accommodations. CSU's Office of Engagement and Extension ensures meaningful access and equal opportunities to participate to individuals whose first language is not English.

Colorado State University Extension es un proveedor que ofrece igualdad de oportunidades. Colorado State University no discrimina por motivos de discapacidad y se compromete a proporcionar adaptaciones razonables. Office of Engagement and Extension de CSU garantiza acceso significativo e igualdad de oportunidades para participar a las personas quienes su primer idioma no es el inglés.

To simplify technical terminology, trade names of products and equipment occasionally will be used. No endorsement of products named is intended nor is criticism implied of products not mentioned.

Members are referred to the Colorado State Fair website for rules regarding entries for the State 4-H Horse Show held at the Colorado State Fair.

2023/2024

4-H Pledge

I pledge my head to clearer thinking,
my heart to greater loyalty,
my hands to larger service,
and my health to better living,
for my club, my community, my country,
and my world.

TABLE OF CONTENTS

Acknowledgments	inside front cover
Colorado State 4-H Horse Show Rules	2
Use of the Name and Emblem of 4-H Club Work	2
Horse Humane Policy Statement	2
Protective Headgear Policy	2
General Rules and Requirements	3
Show Rules and Requirements	4
4-H Horse Drug and Medication Rule	6
Breed Specific Rule.....	6
Definitions and Descriptions	7
General	7
Gaits.....	7
Bits, Curbs and Reins	9
Showmanship Division	15
Western and English.....	15
Questions	19
Patterns (Suggested).....	19
Western Division	21
Western Horsemanship	23
Western Riding	28
Reining	42
Western Dressage.....	65
Trail Division	67
Western and English.....	67
Scoring.....	67
Obstacle Set-up.....	70
Gymkhana Division	74
Individual Events.....	77
Team/Group Events.....	86
Stock Horse Division	87
Heading and Heeling.....	87
Breakaway Roping	90
Steer or Calf Daubing.....	90
Goat Tying/Goat Tail Tying.....	91
Team Penning.....	91
Ranch Horse Division	94
Ranch Horsemanship	96
Ranch Cattle Sorting	110
Ranch Trail	114
Individual Cow Work.....	117
Ranch Cutting	121
Ranch Riding	125
English Division	141
Saddle Seat Equitation and Dressage Seat Equitation.....	143
Hunt Seat Equitation (Not to Jump).....	146
Hunt Seat Equitation Over Fences	151
Hunter Hack	155
English Show Hack Class	157
English Control	158
Dressage	167

Cover art courtesy of: Katelynne Good from Elbert County

COLORADO 4-H HORSE SHOW RULES

Revised 2024

This rulebook provides uniform regulations and procedures for conducting 4-H horse activities in Colorado.

A major goal of the 4-H youth development program is to build and strengthen the youth's character. Good sportsmanship is essential in the 4-H Horse Project competition.

The 4-H Horse Project is designed to emphasize youth development. The program emphasis is on the rider and skills he or she has learned and applied. The horse is a vehicle used to reflect this knowledge and skill learned by the rider. Since the 4-H Horse Project is a learning experience, **disqualification is discouraged**. However, disqualification and/or zero scores are permitted in certain classes. See individual class rules and scoring for further details.

The rules encourage judging and competition that reflect the standards of skills and abilities in horsemanship emphasized by the Colorado 4-H Horse Program.

Use of the Name and Emblem of 4-H Club Work

Use of the name and emblem of 4-H Club Work is regulated by Federal law. This law states that only activities or programs under supervision of Colorado State University Extension may use the name and emblem of 4-H Club Work. Therefore, any local, county, district, area or state 4-H horse show must have the approval of the Colorado State University Extension through county, district or state personnel.

Shows or events sponsored by other organizations or individuals, and shows which do not provide separate classes for 4-H members are not permitted to use the name and emblem of 4-H Club Work. In such cases, the title "Junior Horse Show" or a similar name should be used.

Horse Humane Policy Statement

It is the responsibility of every 4-H member to ensure that proper care is taken of their horse, according to acceptable methods of good equine husbandry, as set forth by Colorado State University Extension and the Colorado Department of Agriculture. A healthy horse requires sufficient food, water, shelter and correct health care. Cruel and inhumane training methods are not appropriate in the Colorado 4-H Horse Program. Specific equine husbandry guidelines and humane training methods are provided in the Colorado 4-H Horse Project manual.

Protective Headgear Policy

A certified equestrian helmet with safety harness fastened in place is required in over fences classes and gymkhana events (i.e., timed events not involving livestock), including all activities associated with these events, such as practice sessions and warm-up. It is the responsibility of the parent or guardian of the 4-H member to see that the headgear worn complies with such standards and is in good condition. **The state 4-H office encourages the use of ASTM certified/SEI approved safety helmets in all equine events.**

Protective headgear may be used in all classes and shall not be discriminated against.

General Rules and Requirements

1. A 4-H member is responsible for knowing the specific rules of the show in which he or she has entered. The rules of this book apply to the Colorado 4-H Horse Program.
2. Colorado 4-H Horse Project members are to be 8 years of age and not yet 19 years old as of December 31 of the enrollment year.
3. The 4-H member should have complete access to the project horse(s) at any time, and **should provide care and management a majority of the time**, whether the horse is owned or leased. A 4-H project horse may be boarded at a commercial facility.
4. Horse Project ID, Primary Care and Sharing of project horses: The horse a 4-H club member intends to use as a project animal must be designated by May 1 of the current year.
 - A. An identification certificate (available online) must be on file with your county extension office. It is recommended that multiple project horses also have an ID certificate filed under the 4-H member's name in case of substitutions.
 - B. All horses entering into the State 4-H Horse Show must be declared a project horse by May 1. Horse hardship substitutions at the State 4-H Horse Show can only be a project horse identified by May 1.
 - C. A horse may be shown by siblings if they show or are entered in different age divisions or classifications at the option of show management or specific county rules.
 - D. Immediate family members may share and ID the same project horse between any number of siblings (each sibling must turn in an ID on the horse). Since the horse is being shared within the immediate family, the same horse may also be IDed/shared by one non-family member.

A horse may be IDed/shared as a project horse by no more than two unrelated 4-H members, if both provide half of the care and management of the animal. One member must be no higher than Level I.
 - E. It is expected that 4-H members include all IDed horses in their E-record Book.
 - F. For all non-owned horses it is recommended a lease agreement be in place to establish responsibilities for care.
5. Counties may have additional ownership, lease, identification, or show rules. Check with your local extension office.
6. The member must keep accurate records and note project progress in the 4-H Horse Project Record Book, attend required 4-H club meetings, and actively participate in the local club and county programs. Members must also own or lease one or more horses which must be identified with the State 4-H

Horse Identification sheet by May 1 of the current year. It is recommended that members give a demonstration or speech, participate in Horse Judging, Horse Bowl, Hippology, or other 4-H activities (at least at the club level). At a minimum, members are required to complete a community service activity and any additional county requirements.

7. Stallions over 1 year of age are prohibited in 4-H.
8. The Colorado 4-H Horse Program has an interest in the welfare of the horse. Horses in poor condition are not representative of a 4-H quality horse. Horses with a Body Condition Score (BCS) of 3 or less may be excused at the judge's discretion. See Horse Project manual for guidelines on BCS.
9. See COLORADO STATE SHOW PREMIUM LIST FOR SPECIFIC RULES RELATING TO THE STATE 4-H HORSE SHOW. (Example rule 4-D: Non-siblings may not share horses at state fair.)
10. Code of Conduct: All Colorado 4-H Horse Project members must adhere to the Colorado 4-H code of conduct.
11. Dress Code: All Colorado 4-H Horse Project members must adhere to the 4-H dress code at all 4-H events.
12. No video protests allowed.
- 13.-19. – NOT ASSIGNED

Show Rules and Requirements

20. Exhibitors, parents, and leaders need to request permission from show management to approach a judge to ask questions or ask for critique. Under no circumstances may an exhibitor, parent, leader or spectator badger, insult or be argumentative with a judge, show secretary, ring steward or show management. Any flagrant display of poor sportsmanship or affront to the judge, ring steward, or show officials/staff by or on behalf of the exhibitor, may result in exclusion of the exhibitor from competition and forfeiture of awards and/or expulsion from the show grounds for the person and/or exhibitor. Refer to the 4-H code of conduct.
21. The management may, at its discretion, expel any person or persons abusing any horse on the grounds at any time, and entry fees and prize money will be forfeited. In any 4-H class, willful abuse or horses showing signs of undue stress or inhumane treatment must be penalized. Any horse exhibited in a class that has evidence of abuse, a cut or abrasion showing clear evidence of fresh blood in the mouth, nose, chin, shoulder, barrel, flank or hip area, must be considered to be ineligible to receive an award in that class. If a body condition score of 3 or less is assigned to any horse by the show manager, judge or veterinarian, that horse is ineligible to compete in any 4-H show or activity.

22. Participation of temporarily or permanently handicapped exhibitors shall be decided by the show management, or the judge, based upon the safety of the individual and/or other exhibitors.
23. Judges will penalize for unsoundness. The severity of penalty is at the judge's discretion. Obvious lameness shall be cause for dismissal from the class, for the safety of rider and welfare of the horse.
24. Riders who do not have their mounts under suitable control will be excused from the ring. Judges and ring officials should interpret this wording to stress safety and courtesy to all riders in the class, and consider a horse as being sufficiently out of control at any time the rider is unable to manage the animal in the required class routine after a reasonable corrective action.
25. A contestant who is handicapped during the class by equipment failure or by the horse casting a shoe, may withdraw or request a 7 minute "time-out" to stop and make repairs. To request a time-out for any such emergency, the competitor must go to the center of the ring (if possible) and/or be acknowledged by the judge. The announcer will declare that a request for time-out has been made and permission granted; time will be taken from the moment such announcement is made. The penalty for exceeding the allowed time out(s) is for the entry to be excused. Two attendants are permitted in the ring to assist a competitor during his/her time-out. If at the expiration of time the repair has not been made, the competitor may proceed as is or be eliminated. The steward or judge is responsible for timing. Competitors who are not involved in a time-out may make minor adjustments that can be performed and not be charged with a time-out. Each exhibitor is allowed only one time-out per class. Following the time-out contestant will then proceed from the point of failure and complete the class. If, in the opinion of the judge, the contestant is able to continue the class in a safe and humane manner, no penalty will be assessed.
 - A. Horse show management should inspect for proper equipment and attire prior to entry into the ring. It is the member's responsibility to review applicable rules for each class.
 - B. A judge or show management shall have the authority to require the removal or alteration of any piece of equipment which, in his/her opinion, would tend to give a horse or rider an unfair advantage. Lack of required appointments or inability to alter prohibited equipment will be penalized at the discretion of the judge.
 - C. Once a class has begun, a pattern may not be changed except as may be necessitated by a safety issue.

D. In consideration of Safety, Animal Welfare or Lameness, at any time the judge(s) considers it necessary he/she may call for a time-out. Said time-out may be charged to a competitor that, in the judge's opinion, is responsible for the suspension of judging as long as the competitor is so informed by the judge prior to calling the class back to order. The judge may ask the exhibitor to come to the center of the ring for the issue to be fixed as outlined previously or be excused depending on the situation/discretion of the judge/show management. It is at the judge's discretion when a gait deficiency effects an exhibitor's placing or the horse's wellbeing to continue in a class. The judge will determine if they believe the horse is serviceably sound for that class or not.

26. Riders will not be asked to change horses in mounted classes because of differences in proper fit of tack.
27. Show management may randomly select and post the order of go for the individual work of classes such as trail, reining, western riding, hunter hack, dressage, English control, etc.

4-H Horse Drug and Medication Rule

28. The Colorado 4-H Horse Program and shows will follow the USEF guidelines for drugs and medications. See the USEF website for a complete guide.

Breed Specific Rule

29. It is the exhibitor's responsibility to inform (and provide documentation) to the show management of acceptable standards for unique breed specifications and attire; all acceptable attire will be judged equally.

30.-39. – NOT ASSIGNED

DEFINITIONS AND DESCRIPTIONS

General

40. Fall of rider: a rider is considered to have fallen when he is separated from his horse, that has not fallen, in such a way as to necessitate remounting or vaulting into the saddle.
41. Fall of horse: a horse is considered to have fallen when the shoulder and haunch on the same side have touched the ground, or an obstacle and the ground.

Gaits

42. The following terminology shall apply in all **Western Classes** whenever a specific gait is called for:
 - A. The walk is a natural, flat-footed, four-beat gait. The horse must move straight and true at the walk. The walk must be alert, with a stride of reasonable length in keeping with the size of the horse.
 - B. The jog-trot is a smooth, ground-covering two-beat diagonal gait. The horse works from one pair of diagonals to the other pair. The jog-trot should be squarely balanced with a straightforward movement of the feet. Horses walking with their back feet and trotting on the front are not considered performing the required gait. When asked to extend the jog, the horse moves out with the same way of going.
 - C. The lope is an easy, rhythmical three-beat gait. Horses moving to the left should lope on the left lead. Horses moving to the right should lope on the right lead. Horses traveling at a four-beat gait are not considered to be performing at a proper lope and are to be penalized. The horse should lope with a natural stride and appear relaxed and smooth. The lope should be ridden at a speed that is a natural way of going.
 - D. Head carriage should be at an angle that is natural and suitable to the horse's conformation.
 - E. Extended gaits – an increased lengthening of the frame and stride.
43. The following terminology shall apply in all Hunt Seat English Classes whenever a specific gait is called for:
 - A. Walk – forward, working walk, rhythmical and flat-footed; extremely slow walk to be penalized.
 - B. Trot – long, low, ground covering, cadenced, and balanced strides. Smoothness is more essential than speed. Excessive speed to be penalized.
 - C. Canter – smooth, free moving, relaxed and straight on both leads. The stride should be suitable to cover ground following hounds. An over-collected or a four-beat canter is to be penalized. Excessive speed is to be penalized.

- D. Hand gallop – should be a definite lengthening of the stride with a noticeable difference in speed. The horse should be under control at all times and be checked and rated easily.
 - E. Extended gaits – an increased lengthening of the stride within the gait.
44. The following terminology shall apply in all **Saddle Seat English Classes** whenever a specific gait is called for:
- A. Walk – four-beat, brisk, true and flat-footed with good reach.
 - B. Normal trot – two-beat gait, to be performed at medium speed with moderate collection. The normal trot must be mannerly, cadenced, balanced and free moving.
 - C. Strong trot or extended trot – two-beat gait, this trot is faster and stronger than the normal trot. It is performed with a lengthened stride, powerful and reaching, at a rate of speed that may vary between horses since each horse should attain his own strong trot in harmony with his own maximum natural stride. The horse must not be strung out behind. He should show moderate collection without exaggerated high action in front. He must present a willing attitude while maintaining form. The strong trot must be mannerly, cadenced, balanced and free moving.
 - D. Canter – three-beat gait, smooth, and unhurried with moderate collection, correct and straight on both leads.
45. Gaited horses will show at the walk and intermediate gaits according to breed standards. Canter/Lope may be required according to breed standards

46. Lead Changes

- A. Simple Lead Changes- A simple lead change is a lead change made through a transition down to the jog or walk for one to three strides and then back to the lope/canter on the other lead.
- B. Flying Lead Changes- Flying changes should be simultaneous front and rear without breaking gait. All changes should be smooth and timely with limited or minimal change to the horse's frame and are not dependent on a change of direction.
- C. Some patterns require simple or flying lead changes based on level. However, when levels are mixed it is the judge's discretion as to when a proper simple change begins to outscore a poorly executed flying change. Properly executed flying changes are generally considered a higher degree of difficulty when performed as outlined in 46.B and would score higher than simple changes but properly executed simple changes should not be penalized when levels are mixed and can be credit earning.

47.-49. – NOT ASSIGNED

BITS, CURBS AND REINS

English Class Bits

50. When showing in **English Performance Classes**, USEF (United States Equestrian Federation) regulation snaffles, pelhams or full bridles (all with cavesson nosebands) are required. Kimberwick bits are acceptable. Pelham bits must have two reins; however, a single rein may be used with a Pelham bit, if conversion straps are used.
51. When showing in **Dressage Classes**, horses will be shown in plain, smooth snaffles. A snaffle bit is considered to be a plain, smooth-mouth snaffle if made with a solid surface of the same metal, rubber or plastic. A snaffle bit must be a minimum of 5/16 inch in diameter at the rings or cheeks of the mouthpiece. Flexible rubber or synthetic mouthpieces are permitted, but the bit may not be modified by adding latex or other material.
52. Prohibited: Triangular (fishback) bits, snaffles less than 5/16 inch in diameter and English ports over 3-1/2 inches in height. Refer to the current USEF Rulebook for legal bits in the English Divisions, when not covered in the Colorado 4-H Rule Book.

ACCEPTABLE DRESSAGE BITS

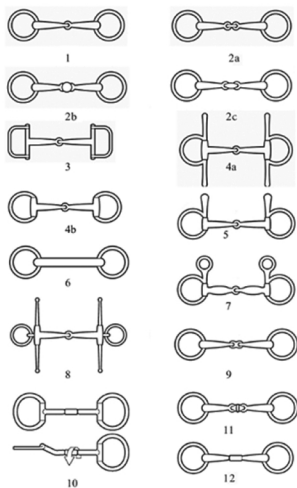

1. Ordinary snaffle with single-jointed mouthpiece.
2. (a, b, c) Double-jointed snaffles.
3. Racing snaffle (D-ring).
4. Snaffle.
 - a) with cheeks, with or without keepers.
 - b) without cheeks (Egg-butt).
5. Snaffle with upper or lower cheeks.
6. Unjointed snaffle (Mullen-mouth).
7. Snaffle with cheeks. (Hanging or drop cheek; Baucher). This may be a D-ring or other ordinary snaffle as pictured in Nos. 1-6.
8. Fulmer.
9. French snaffle.
10. Snaffle with rotating mouthpiece.
11. Snaffle with rotating middle piece.
12. Happy Mouth with roller.

ADDITIONAL BITS ACCEPTABLE FOR ENGLISH



Slow Twist Full Cheek Snaffle

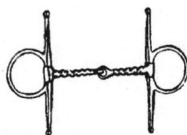

Corkscrew Full Cheek Snaffle

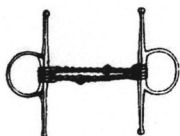

Double Twisted Wire Full Cheek Snaffle



Single Twisted Wire Full Cheek Snaffle

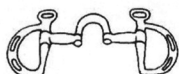

Correction Bit Kimberwick



O-Ring Snaffle Bit with Connecting Flat Link



Full Cheek Snaffle with Broken Mouthpiece



Low Port Kimberwick



Pelham bit with Mullen Mouth



Full Bridle bits – Sliding Weymouth (curb) and bradoon (snaffle) with broken mouthpiece

UNACCEPTABLE ENGLISH BITS

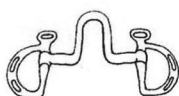

Excessive Port

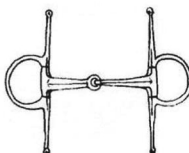

Triangular Mouth

Western Class Bits

53. Whenever this rulebook refers to hackamore, it means the use of a rawhide-braided, leather-braided or rope bosal. It does not refer to a so-called mechanical hackamore or side pulls. Absolutely no metal will be permitted under the jaws regardless of how padded or covered when using a hackamore.
54. Whenever this rulebook refers to a snaffle bit in Western performance and Ranch Horse classes:
- It means the use of a non-leverage bit (conventional O-ring, egg-buttor D-ring) with a ring no larger than 4 inches. The bit, when measured 1 inch in from the cheek, must be a minimum of 5/16" diameter with a gradual decrease to center of the snaffle and must be smooth. Optional loose curb strap allowed (leather or nylon only). **The reins must be free to slide around the rings so it does not create leverage.**
 - Chain curbs are prohibited on snaffle bits.

SNAFFLE BITS ACCEPTABLE FOR BOTH ENGLISH AND WESTERN



Eggbutt



D-Ring

55. Whenever this rule book refers to a bit in **Western and Ranch Horse Performance Classes**:
- It means the use of a curb bit that has a solid or broken smooth mouthpiece, is a minimum of 5/16" and maximum of 3/4" in diameter, has shanks (shanks to be no longer than 8 1/2") and acts with curb action. Curb straps or chains are required.
 - Mechanical hackamores, chain or gag bits are prohibited in Western Performance and Ranch Horse Classes.

BASIC WESTERN MOUTHPIECE STYLES



Broken Mouth



Roller or Cricket Mouth



Low and Medium Port Mouth
 Low or Medium Acceptable
 Excessive Port Unacceptable
 (greater than 3 1/2")



Correction Mouth



*Sweet Iron
 Low Port Bit*

Legal Bit

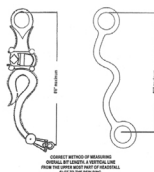

56. Refer to the current American Quarter Horse Association (AQHA) Rules when bits are not listed in the Colorado 4-H Rule Book for the Western Divisions.
57. Curbs—Chain curbs or curb straps must be at least 1/2 inch in width and lie flat against the jaws of the horse. No wire, metal or rawhide may be used in conjunction with, or as part of, the flat leather chin strap, which must be at least 1/2 inch in width. Round, rolled, braided or rawhide curb straps are prohibited.

ACCEPTABLE CURBS



UNACCEPTABLE CURBS



Not Legal – Round Leather -
too narrow at chin, not flat



Not Legal – Round Leather -
too narrow across, not flat



Not Legal – Round Braided Leather -
wide enough, but rough and not flat



Not Legal – Braided Leather (Rawhide) -
too narrow and too rough



Not Legal – Single Link Chain -
if under 1/2" wide

58. When this rulebook refers to romal, it means an extension of material attached to closed reins.
- A. This extension is to be allowed to be carried in the free hand with a minimum of a 16-inch spacing between the reining hand and the free hand holding the romal.
- B. The romal shall not be used forward of the cinch or used to signal, or cue the horse in any way. Any infraction of this rule shall be penalized severely by the judge.

- C. When using a romal, the rider's hand **must** be around the reins. No finger is permitted between the reins of the romal. Fingers are allowed between the romal and the mecate when riding with a two rein outfit.
- D. Use of a get down rope is permitted when riding with a romal. A get down will be defined as a small rope tied around the neck of a horse and run back to the rider or tied to the saddle and used to lead, ground tie, or tie the horse. The get down rope may also be run through a bosilita. The bosilita may be hung with a hanger or a forelock string and must not restrict the horse from opening his mouth.



Image above: The correct method for holding romal reins. If the romal is excessively long, it is acceptable to have one coil in the offside hand.

59. Split Reins. Two different and correct methods of holding split reins while riding with a curb bit are shown as follows:

- A. When using split reins, only the index finger of the reining hand between the reins is permitted. When held in this manner the reins are to go through the hand from top to bottom with the bight of the rein on the side of the reining hand.



- B. No finger is permitted between split rein, when the reins are held from the bottom of the hand up through the top of the hand and the bight of the reins is held in the opposite hand (as in the style of the romal rein).



60. For hackamore and snaffle-bit horses [5 years and under].

- A. Entries to be shown with both hands on reins, maintaining light contact with the horse's mouth. The rider's hands should be carried near the pommel and not further than 4 inches out from either side of the saddle horn. Rider's hands must be steady with very limited movement. Rider's hands must be visible at all times. Reins must be bridged between the hands.

ACCEPTABLE

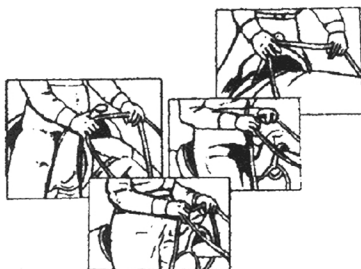

UNACCEPTABLE

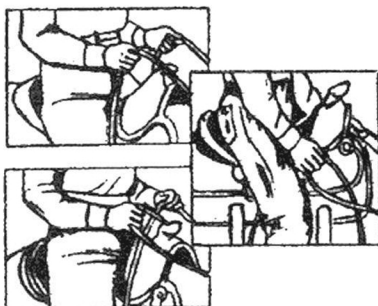

61. Holding a Mecate

- A. To hold **the mecate** correctly grasp the rein with both hands with your knuckles up and your thumbs facing inward. As you grasp take a loop in the excess mecate and hold the loop with the rein in your left hand. Be sure to leave enough length between your hands that they are approximately shoulder width apart. The excess length of rope in the loop can be used to shorten and lengthen the mecate as needed while you ride. (*Quarter Horse News*)

62.-69. – NOT ASSIGNED

SHOWMANSHIP DIVISION

Western and English

70. Showing a horse at halter is an art and should be considered as such by the showman and judge alike. Proper showmanship testifies to the obvious pride the showman has in the animal being exhibited. This pride is evidenced by the condition and appearance of the horse and by the actions of the exhibitor and horse in the ring, which indicate previous training to form a coordinated team. Conformation of the horse is not judged since the horse is considered a means of displaying the abilities of the showman.
71. Technical points and minor infractions of rules should not be over-emphasized to the extent they outweigh an effective job of presenting a clean, well-conditioned, trained animal.

Class Routine

72. Showmanship is designed to evaluate the exhibitor's ability to execute, along with a well groomed and conditioned horse, a set of maneuvers prescribed by the judge with precision and smoothness while exhibiting poise and confidence. Exhibitors should be courteous and sportsmanlike at all times, quick to recognize and correct faults in the positioning of the horse. The exhibitor should continue showing the horse until the class has been placed. The exhibitor should appear business-like, stand and move in a natural manner, and avoid excessive, unnatural or animated body positions.
 - A. Exhibitors may be asked to enter one at a time into the ring or to line up as a class in the arena.
 - B. Exhibitors will complete a pattern individually before the judge and return to line up.
73. Explanation of judging criteria
 - A. **Showing the Horse**
 1. Ring Conduct
 - a. The exhibitor should be ready when the class is called, entering the ring in a brisk, alert manner. Circling in a counter-clockwise direction is preferred, ***but follow instructions given by the ring steward.***
 - b. The exhibitor should remain attentive for any instructions from the ring steward or judge.
 - c. Showmanship is practiced from the time of entering the ring until retired from the ring after the class is completed.

2. Leading

- a. Lead from the left (near) side of the horse. The horse should be led so that its head and neck are carried in a natural position. This necessitates that the lead shank be held some distance from the halter. This distance will depend upon the size and conformation of the horse and the stature of the exhibitor. The lead shank should be held in the right hand. The remaining portion of lead is held neatly and safely in left hand. Either a loose loop lead or figure eight is acceptable. The lead shank should never be wrapped around a hand for safety reasons.
- b. The horse should move readily and freely at a walk or trot with minimum urging by the exhibitor. The exhibitor should stay in position by the left (near) side of the horse's neck, preferably half-way between the horse's head and shoulder. A well-trained horse will move readily at a speed of gait equal to the speed at which the exhibitor is moving.

3. Set-Up/Presentation

- a. When setting up your horse, stand toward the front facing the horse, but not directly in front of the horse, and always in a position where you can keep your eye on the judge.
- b. ***Exhibitor should show in the manner and custom appropriate for the breed shown. See Rule 29.***
- c. The horse should set up quickly, stand quietly and correctly, and move forward or back freely.
- d. Do not crowd the exhibitor next to or in front of you. Leave a safe distance between horses.

B. Appearance of Horse

1. Condition of Horse

- a. Smooth, glossy coated, showing hard rippling muscles.
- b. Displays alertness and vigor.
- c. A loose pliable skin that is clean and healthy, with fine, smooth, glossy hair.
- d. Evidence of a correct balance of nutrition, care and exercise.
- e. Excess fat or a thin, unthrifty condition are objectionable.

2. Grooming

- a. Clean, well-brushed hair coat. Dust, dandruff, wet hair, sweat, and stains are objectionable.
- b. Areas around the eyes, ears, muzzle, nostrils, between the legs and around the tail should be clean.

- c. Grooming of the mane and tail should correspond to breed standards. The mane and tail must be clean, neat, and free of snarls.
 - d. Feet should be clean and the hooves properly and appropriately trimmed, or shod. Hoof dressing most commonly used by the breed may be used.
3. Tack
- a. Should be neat, clean and properly adjusted.
 - b. Western: appropriate show halter and lead shank. Showing in a halter with a chain is acceptable. Chains, if used, should be used under the jaw. Lip chains or chains over the nose are not allowed.
 - c. Silver or other decorations should not be given preference over clean, workable tack.
 - d. English: exhibitors may show in a plain leather or nylon halter, or in a bridle. If showing with a bridle and using reins to lead the horse, the buckle must be undone. The exhibitor may choose to use a lead shank attached to the bit or a cavesson with the reins safely draped over the horse's withers. Silver western halters are not permitted when dressed in English attire.
 - e. Rope halters or "bronc" halters are not permitted.

C. The Exhibitor

1. Appearance
- a. A neat, clean appearance is desired.
 - b. Appropriate clothing; well-fitted and in good taste. Expensive clothing is not necessary.
 - c. Pants should be clean and neat.
 - d. Hat should be clean and shaped.
 - e. Boots should be clean and shined.
 - f. Spurs prohibited.
2. Dress. See sections in Western Division (#90) Saddle Seat (#400), and Hunter Seat Equitation (#402). Showman may be attired according to breed standards which may not require a hat. See Rule 29.
3. Poise
- a. Keep alert and be aware of the position of the judge at all times. Do not be distracted by persons or things outside the ring.
 - b. Show the animal at all times, not yourself.
 - c. Respond quickly to requests from the judge and officials.
 - d. Be courteous and sportsmanlike at all times.
 - e. Recognize quickly, and correct any faults of your horse such as resting a foot or running a leg out of position.
 - f. Keep showing until the entire class has been placed and/or excused from the ring.

Scoring

74. Judge should use the showmanship score card. Exhibitors are to be scored from 0 to infinity, with 70 denoting an average performance. Patterns will be divided into 6 to 10 maneuvers, as specified by the judge, and each maneuver will be scored from +3 to -3 with 1/2 point increments acceptable that will be added or subtracted from 70. Maneuver scores should be determined independent of penalties, and should reflect equal consideration of both performance of the exhibitor's pattern and the form and effectiveness of the exhibitor and presentation of horse to result in the following scores: +3 Excellent, +2 Very Good, +1 Good, 0 Average or Correct, -1 Poor, -2 Very Poor, -3 Extremely Poor. Exhibitors overall form and effectiveness should also be scored from 0 to 5 with 0 to 2 Average, 3 Good, 4 Very Good, 5 Excellent.

Penalties

75. Maneuver evaluations and penalty applications are to be determined independently. The following penalties will be applied for each occurrence and will be deducted from the final score:

A. Minor One (1) Point Penalties:

1. Break of gait at the walk or trot up to 2 strides
2. Over or under turning up to 1/8 of a turn
3. Ticking or hitting cone
4. Sliding a pivot foot
5. Lifting a pivot foot during a pivot and replacing it in the same place
6. Lifting a foot in a set-up and replacing it in the same place after presentation
7. Horse resting a foot or hipshot in a set-up

B. Major Three (3) Point Penalties:

1. Not performing the specific gait or not stopping within 10 feet (3 meters) of designated location
2. Break of gait at walk or trot for more than 2 strides
3. Splitting the cone (cone between the horse and exhibitor)
4. Horse stepping out of or moving the hind end significantly during a pivot or turn
5. Horse stepping out of set-up after presentation
6. Over or under turning 1/8 to 1/4 turn

C. Severe Five (5) Point Penalties:

1. Exhibitor is not in the required position during inspection
2. Exhibitor touching the horse or kicking or pointing their feet at the horse's feet during the set-up
3. Standing directly in front of the horse
4. Loss of lead shank, holding chain or two hands on shank
5. Blatant disobedience including biting, kicking, rearing or pawing; horse continually circling exhibitor

D. Zero Scores (Eligible for placing but not above anyone receiving a score above zero):

1. Off pattern
2. Knocking over or wrong side of cone or marker
3. Failure to perform or achieve the specified gait
4. Over /under turn more than 1/4 turn

E. Disqualifications (should not be placed):

1. Loss of control of horse
2. Illegal Equipment
3. Horse becomes separated from exhibitor
4. Willful abuse
5. Excessive schooling or training

Questions

76. The judge may ask questions of the exhibitors. Questions should be appropriate for the age level of the exhibitor and the same or similar question(s) should be used for each exhibitor in the same class.

Examples of Patterns

77. Individual judges or show management may select patterns not included in these rules. It is the exhibitor's responsibility to check for posted patterns prior to the start of the show.
- A. Numerous patterns are acceptable for showing the horse's way of going. Show management should designate the pattern to be used, considering show ring space available and judge's preference. The basic points of proper handling apply in all patterns.
- B. Where individual style of judging is used, the show management must post the class pattern at least 1 hour prior to the class.

78. Pattern 1

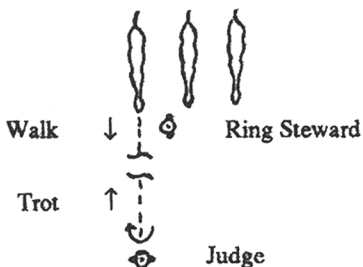

Class remains in line with horses facing the judge. Each exhibitor leads horse at a walk to judge upon a signal, halts a horse length away. Judge will inspect the horse. When dismissed, exhibitor will turn 180° and trot away from judge to the line, walks through the line, turns to the right and re-enters the line quietly. Ring steward and exhibitors should be alert to prevent accidents. This pattern may be run in reverse by trotting to the judge and returning to the line at a walk.

The judge then moves to a position opposite the next horse in line and indicates to the exhibitor when he is ready. This is repeated to the end of the line.

79. Pattern 2

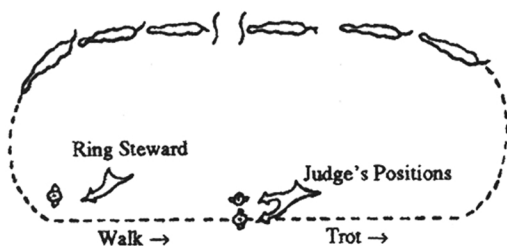

The class is lined up head to tail at one side of the arena or outside entry gate. Each horse is led to a point indicated by the ring steward. This point should be in a straight line to the position assumed by the judge. The horse should be set up for inspection by the judge unless directed otherwise. The exhibitor should use care and travel in a straight line to and beyond the judge so the horse's action will be balanced and true. The exhibitor then turns and assumes a place at the end of the class line.

The judge may call for the exhibitor to set the horse up between the walk and the trot.

80.-89. – NOT ASSIGNED

WESTERN DIVISION

90. Personal Attire: Western Dress Code

- A. Western clothing that reflects neat, clean, well-fitted work-like appearance. Expensive clothing will not count over neat, clean clothing.
- B. Western hat, Western or cowboy boots, belt and long-sleeved, full-length shirt (chest and midriff covered) required. Any exhibitor may wear certified equestrian protective headgear in any division or class without penalty. A certified equestrian helmet with safety harness fastened in place is required in gymkhana events, activities and practice sessions.
- C. Optional: gloves, ties, chaps, vests, jackets, raincoat and spurs. See classes for exceptions.
- D. Certified helmets are allowed and encouraged in all western classes and shall not be discriminated against in the adjudication of the class.
- E. Any exceptions will be listed under specific classes.

91. Equipment

- A. Horses shall be shown with a stock saddle with horn; silver equipment will not count over a good working outfit. Western bridles with a standard western curb bit that has a solid or broken smooth mouthpiece, is a minimum of 5/16" and maximum of 3/4" diameter, has shanks and acts with curb action; romal or split reins.
- B. Bosals and snaffle bits are allowed on horses 5 years old and under. When ridden in a bosal or a snaffle bit, two hands must be used on reins or mecate.
- C. Horses 6 years old and older must be shown in a standard western bit with shanks and ridden with one hand.
- D. Optional Equipment:
 - 1. Rope or riata. If used, the rope or riata must be coiled and attached to the saddle. Ranch Horse Classes Only.
 - 2. Hobbles – attached to saddle.
 - 3. Breast collar, rear cinch, crupper, tapaderos.
- E. Prohibited Equipment:
 - 1. Wire curb straps regardless of how padded or covered.
 - 2. Any curb strap narrower than 1/2 inch.
 - 3. Martingales, nosebands, tie-downs, whips, bats or quirts, roping or closed rein.
 - 4. Curb bit with shanks over 8 1/2 inches maximum, measured from the top ring (under the circle) where the cheek piece attaches to the bit; down to the lower ring where the reins attach to the shank of the bit.

5. Mechanical hackamore, chain or gag bits.
 6. Splint boots, leg wraps, bell boots, etc. shall not be used for any classes in this division, except reining. However, in the event of injury, a protective bandage is permitted.
92. Spurs or romal shall not be used forward of the cinch. Spurs must be dull or have a free moving rowel.
93. Equipment for gymkhana events.
- A. In gymkhana events (timed events), western-type equipment must be used. Use of a hackamore (including mechanical hackamores) or other types of bridles or bits is the optional choice of the contestant; however, the judge or show official may prohibit the use of bits or equipment he/she may consider severe. Riders should check with show officials regarding any equipment which may be considered unconventional.
 1. Required Equipment:
 - a. ASTM/SEI approved safety helmet with harness securely fastened. A certified equestrian helmet with safety harness fastened in place is required in gymkhana events, activities and practice sessions (i.e., timed events not involving livestock). It is the responsibility of the parent or guardian of the 4-H member to see that the headgear worn complies with such standards and is in good condition.
 2. Optional Equipment:
 - a. tie-downs
 - b. whips or bats
 - c. skid, splint, or bell boots
 - d. roping or closed reins
 3. Prohibited Equipment:
 - a. jerk lines
 - b. tack collars
 - c. draw reins
 - d. any attachment between the foot and the stirrup including rubber bands
94. The judge or show official, at his/her discretion, may disqualify a contestant for excessive use of a bat, crop, whip or rope, or for use of this equipment in front of the cinch.
- 95.-99. – NOT ASSIGNED

WESTERN HORSEMANSHIP

Also known as (Western Equitation; Stock Seat Equitation)

General

100. Seat and Hands

- A. Riders will be judged on hands, basic position, position in motion and designated class procedures.
- B. Results as shown by performance of the horse are NOT to be considered more important than the method used by the rider in obtaining them.

101. Hands

- A. Upper arms to be in a straight line with body; the one holding reins is bent at the elbow. Reins will be held in one hand, where required, and cannot be changed during performance. Reins are to be carried immediately above and as near to the saddle horn as possible. The free hand is held near waist or neatly down on the rider's leg.
- B. See rule 58 for guidelines on romal use.
- C. See rule 59 for guidelines on split rein use.
- D. See rule 60 for guidelines on hackamore and snaffle bit horses.
- E. See Rule 61 for guidelines for Mecate rein use.

102. Basic Position

- A. Rider should sit in the saddle with knees slightly bent and weight directly over the balls of the feet. The stirrup should be just short enough to allow heels to be lower than toes.
- B. The body should always appear comfortable, relaxed and flexible.
- C. Feet should be placed in the stirrups with weight on the ball of the foot.
- D. Consideration, however, should be given to the width of the stirrups, which may vary on western saddles. If stirrups are wide, the foot may have the appearance of being "home" when in reality the weight is being properly carried on the ball of the foot.

103. Position in Motion

- A. All movements of horse should be governed by the use of imperceptible aids. Exaggerated shifting of the rider's weight is not desirable. The rider should sit to jog and not post.
- B. The rider should be close to saddle at the lope.

104. Mounting and Dismounting

- A. The horse should stand while mounting until given the signal to move out. Control the horse by taking the reins in left hand and adjusting reins evenly with enough tension to feel the bit and hold the horse steady. Ends of the reins fall on the near side while mounting. Rein hand may be placed on the neck while mounting.
- B. Facing the horse, place the left foot in stirrup (if necessary, twist stirrup with right hand). Grasp the saddle horn with your right hand. Spring up with your right leg keeping your body close to the horse and settle easily into the saddle.
- C. Slip the right foot into the off stirrup.
- D. To dismount, the left stirrup should be positioned on the ball of your foot and then reverse the above procedure; step or slid down (size of rider should be considered). Rider must maintain rein control of the horse while dismounting.

105. Appointments and Tack

A. Required

- 1. Personal: See Western Personal Attire (#90).
- 2. Tack: See Western Equipment (#91).

B. Optional Appointments: Chaps

106. Class Routine: The horse should be in balance at all times, working off its haunches with its head at a normal height for its conformation. A Western horse responds smoothly and instantly to all aids showing lightness and freedom of action.

- A. When on the rail, the class will enter ring at a walk or jog as requested and proceed in a counter-clockwise direction. The class will be worked at a walk, jog, and lope, in both directions of the ring, and horses should always be on the correct lead, riding without evidence of undue restraint.
- B. The class may be asked to extend gaits, reverse at a walk or jog, stop, or other individual tests requested by the judge.
- C. As determined by the agreement of show management and the judge, the class may be evaluated as follows:
 - 1. On the rail – both directions at all gaits, or
 - 2. Individual tests, i.e., pattern work, or
 - 3. In combination: pattern work and rail work, which may be one or both ways of the arena. The judge's opinion shall rest on an analysis of the rail work and the individual tests.

Scoring

107. Judges should use the 4-H Horsemanship Score card. Exhibitors are to be scored from 0 to infinity, with 70 denoting an average performance. Patterns will be divided into 6 to 10 maneuvers, as specified by the judge, and each maneuver will be scored from +3 to -3 with 1/2 point increments acceptable that will be added or subtracted from 70. Maneuver scores should be determined independent of penalties, and should reflect equal consideration of both performance of the exhibitor's pattern and the horsemanship form and effectiveness of the exhibitor to result in the following scores: +3 Excellent, +2 Very Good, +1 Good, 0 Average or Correct, -1 Poor, -2 Very Poor, -3 Extremely Poor. Exhibitors' overall horsemanship form and effectiveness should also be scored from 0 to 5 with 0 to 2 Average, 3 Good, 4 Very Good, 5 Excellent. Exhibitors can also be judged on the rail, and their pattern score and/or ranking may be adjusted as appropriate.

Penalties

108. Maneuver evaluations and penalty applications are to be determined independently. The following penalties will be applied for each occurrence and will be deducted from the final score:

A. Minor One (1) Point Penalties:

1. Break of gait at the walk/jog or wrong lead up to 2 strides
2. Over or under turn 1/8 of designated turn
3. Over cueing with reins and/or legs
4. Reins too long/short or uneven
5. Failure of horse to stand still at end of pattern
6. Obviously looking for lead
7. Tick or hit of cone

B. Major Three (3) Point Penalties:

1. Not performing the specific gait or not stopping within 10 feet (3 meters) of designated location
2. Incorrect lead for more than 2 strides
3. Break of gait at the lope (except when correcting an incorrect lead)
4. Break of gait at walk or jog for more than 2 strides
5. Over or under turn from 1/8 to 1/4 turn

C. Severe Five (5) Point Penalties:

1. Blatant disobedience including kicking, pawing, bucking, and rearing
2. Loss of stirrup or rein
3. Touching the horse or saddle

4. Cueing with the end of the romal
5. Spurring in front of the cinch
6. Use of free hand to instill fear or praise

D. Zero Scores (Eligible for placing but not above anyone receiving a score above zero):

1. Off pattern
2. Wrong side of cone or knocking over cone
3. Failure to perform or achieve the specified gait or lead
4. Over/under turn more than 1/4 turn

E. Disqualifications (should not be placed):

1. Loss of control of the horse
2. Illegal Equipment or illegal use of hands on reins
3. Fall by horse or exhibitor (pg. 7 rule 40 and 41)
4. Abuse of horse or schooling

109. Maneuvers the Judge may include in patterns (care should be taken that requested maneuvers not exceed rider's ability)

A. Unrated and Advancement Level I Riders

1. Individual performance on the rail
2. Circle at jog or lope on the correct lead
3. Lope and balanced gradual stop
4. Back

B. Advancement Level II Riders

1. Any of the above
2. Simple lead change. (Simple change is when the horse is brought back to a walk or jog at the point of change and transition to a lope on the opposite lead.) See page 8, rule 46.
3. Figure 8 at lope on correct lead, demonstrating simple change of leads. Figure 8 should be started in center of two circles so one lead change is shown.
4. Ride without stirrups
5. Turn on forehand, 90° or 180°
6. Turn on hindquarter, 90° or 180°

C. Advancement Level III Riders

1. Any of the above
2. Figure 8 at lope on correct lead executing a flying change of lead
3. Execute flying change of lead at each change of direction on a serpentine. See page 8, rule 46.

4. Execute a smooth, balanced stop
 5. Controlled turn on hindquarters (at least 180° turn both directions)
 6. Sidepass either direction
 7. Extended gaits
 8. Counter-canter
 9. Turn on forehand 360°
 10. Turn on hindquarter 360°
 11. Twotrack at a walk or jog (either or both directions)
- D. Advancement Level IV Riders
1. Any of the above
 2. Roll backs
 3. Two track (either or both directions), any gait
 4. Flying change of lead on straight away. See page 8, rule 46.
 5. Spins
 6. Sliding Stops

110.-114. – NOT ASSIGNED

WESTERN RIDING

General

Western riding is a precision performance class.

115. The performance required in this class is designed to reflect a combination of controls and skills used in equitation, reining and trail classes.
116. The horse is judged on quality of gaits, lead changes, response to the rider, manners and disposition. The horse should perform with reasonable speed, and be sensible, well-mannered, free and easy moving.
117. Each rider will perform individually. He or she will be judged upon the skills shown in executing the required pattern.
118. When levels are mixed and the judge agrees, properly executed flying changes will score higher than simple changes on all patterns. It is the judge's opinion as to when a proper simple change begins to outscore a poorly executed flying change.

When simple changes are required, a flying lead change should be penalized and not be scored higher than a well-executed simple lead change.

119. Credit shall be given for and emphasis placed on smoothness, even cadence of gaits (i.e., starting and finishing pattern with the same cadence), and the horse's ability to change leads precisely, and simultaneously, rear and front, at the center point between markers. Gaits are to be performed as described in #42. The horse should have a relaxed head carriage showing response to the rider's hands, with a moderate flexion at the poll. The horse should negotiate the pattern in an easy fashion, neither diving into nor rushing through the markers. The horse should cross the log both at the jog and lope without breaking gait or radically changing stride.
120. Judge and/or show management shall select appropriate patterns. Patterns A-F shall be used for Level I, Level II, and unrated classes at county option. Patterns 1-4 shall be used for Level III and Level IV classes. The patterns and routine are prescribed. It is essential that the judge and exhibitors adhere to them.
 - A. The small squares represent markers (cones or standards recommended). These should be separated by a uniform MEASURED distance of not less than 30 nor more than 50 feet on the side with five markers (see diagram). The judge is responsible for correctness of the pattern.
 - B. The rectangle represents an obstacle (one small log recommended), minimum of 8 feet in length.
 - C. The long and sometimes twisting line with arrows indicates the direction of travel, and the gaits at which the horse is to move. The dotted line (...) indicates walk, the dash line (---)jog, and the solid line lope.

121. Only one hand on the reins is permitted and must not be changed, except for junior (5 years and under) horses shown in a bosal or snaffle bit.

Scoring

122. Score will be on a basis of 0-100 with 70 denoting an average score. Use of the 4-H Western Riding score card is recommended and may be posted after the conclusion of the class. A scribe may be provided for the judge. Management should encourage the posting of the western riding score card as a learning tool for the exhibitors.
123. Scoring guidelines to be considered: points will be added or subtracted from the maneuvers on the following basis, ranging from plus 1.5 to minus 1.5: -1.5 Extremely Poor, -1 Very Poor, -.5 Poor, 0 Average, +.5 Good, +1 Very Good, +1.5 Excellent. Maneuver scores are to be determined independently of penalty points.
124. Contestants shall be penalized each time the following occur.

A. Five (5) points for:

1. out of lead beyond the next designated change area (failure to change, cross-canter; two consecutive failures to change would result in two five point penalties)
2. blatant disobedience (biting, kicking out, bucking, etc.)

B. Three (3) points for:

1. not performing the specific gait (jog or lope) or not stopping when called for in the pattern, within 10 feet of the designated area
2. break of gait at lope
3. out of lead at or before the marker prior to the designated change area (see E. diagram)
4. out of lead at or after the marker after the designated change area (see E. diagram)
5. additional lead changes anywhere in pattern (except when correcting an extra change or incorrect lead)
6. in pattern A and in pattern one, failure to start the lope within three strides or 30 feet after crossing the log at the jog
7. break of gait at walk or jog for more than two strides
8. flying lead change where a simple lead change is required (patterns A, B, C, D, E and F)
9. simple lead change where a flying lead change is required (patterns 1, 2, 3 and 4)

C. One (1) point for:

1. break of gait at walk or jog up to two strides
2. hitting or rolling log

3. out of lead more than one stride on either side of the designated lead change area (see E. diagram)
4. splitting the log (log between the two front or two hind feet) at the lope

D. One-half (1/2) point for:

1. tick or light touch of log
2. hind legs skipping or coming together during lead change
3. non-simultaneous lead change (front to hind or hind to front)

E. Location Penalties for Designated Change

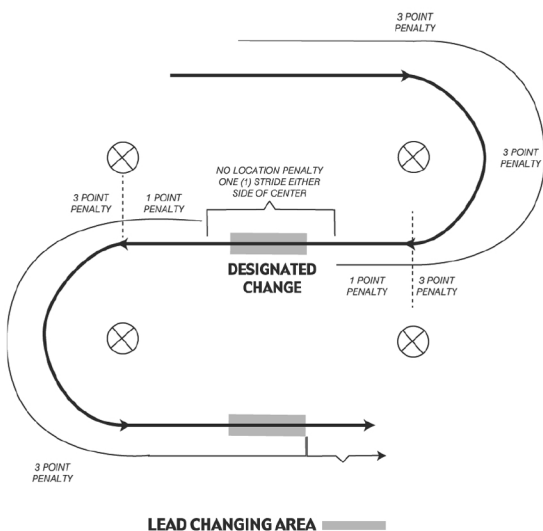
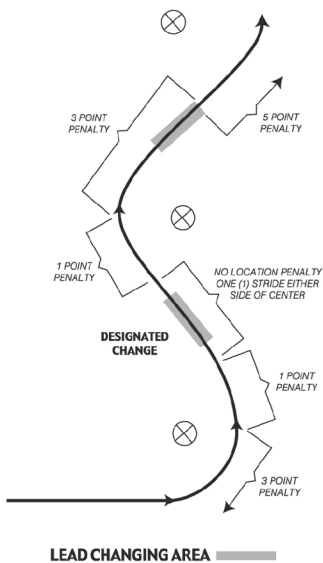

F. Disqualified or zero (0) score which is not to be placed:

1. illegal equipment
2. willful abuse
3. off course
4. knocking over markers
5. completely missing log
6. major refusal (stop and back more than two strides or four steps with front legs)
7. major disobedience (rearing, schooling)
8. failure to start lope prior to end cone in pattern one
9. failure to change leads 4 or more times

G. A contestant shall be credited for:

1. changes of leads, hind and front simultaneously
2. changes at designated point
3. accurate and smooth pattern
4. even pace throughout
5. easy to guide and control with rein and leg
6. manners and disposition
7. conformation and fitness

H. The following characteristics are considered faults and should be judged accordingly in maneuver scores.

1. Opening mouth excessively
2. Anticipating signals or early lead changes
3. Stumbling

125. Pattern A – Level I Western Riding

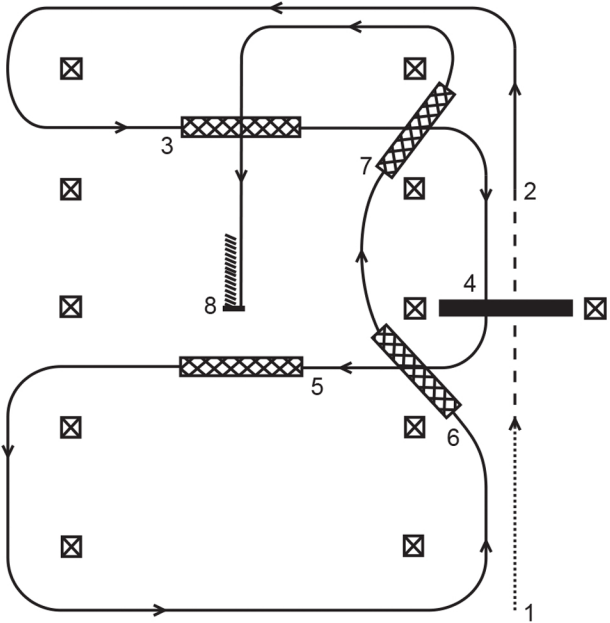

Walk: Lope: _____
 Back: //////////////// Jog: - - - - -
 Lead Changing Area: [XXXXXXXXXX]

Simple lead changes are required, flying changes to be penalized. See rules 118 and 124.B.8.

1. Walk at least 15' and jog over pole.
2. Transition to lope.
3. First crossing change.
4. Lope over log.
5. Second crossing change.
6. First line change.
7. Second line change.
8. Lope to center, stop and back.

This pattern could be used for level 1 when choosing Western Riding Pattern Number 1.

126. Pattern B – Level I Western Riding

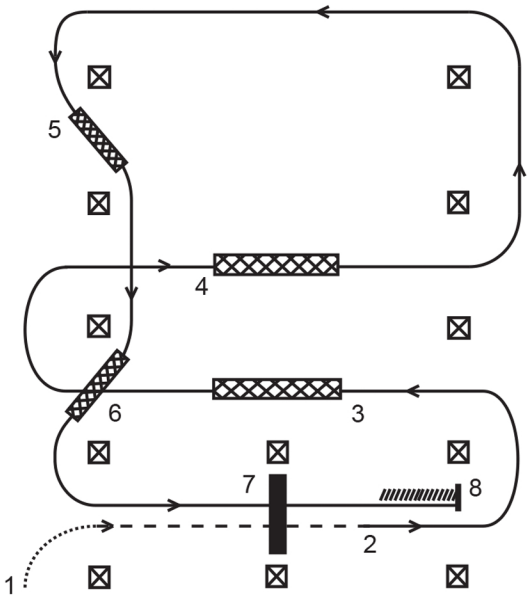

Walk: Lope: _____
 Back: // Jog: - - - - -
 Lead Changing Area: [XXXXXXXXXX]

Simple lead changes are required, flying changes to be penalized. See rules 118 and 124.B.8.

1. Walk, transition to jog, jog over log.
2. Transition to lope.
3. First crossing change.
4. Second crossing change.
5. First line change.
6. Second line change.
7. Lope over log.
8. Stop and back.

This pattern could be used for level 1 when choosing Western Riding Pattern Number 2.

127. Pattern C – Level I Western Riding

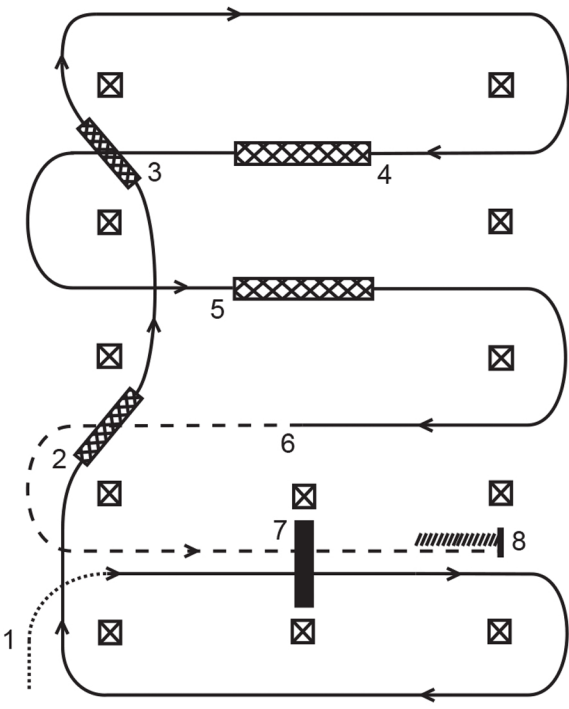

Walk: Lope: _____
 Back: //////////////// Jog: - - - - -
 Lead Changing Area: [XXXXXXXXXX]

Simple lead changes are required, flying changes to be penalized. See rules 118 and 124.B.8.

1. Walk, transition to lope, lope over log.
2. First line change.
3. Second line change.
4. First crossing change.
5. Second crossing change.
6. Transition to jog.
7. Jog over log.
8. Stop and back.

This pattern could be used for level 1 when choosing Western Riding Pattern Number 4.

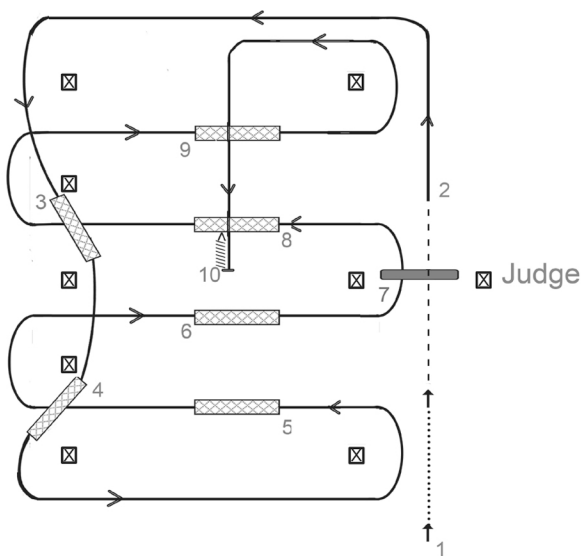

Walk: Lope: _____
 Back: // Jog: - - - - -
 Lead Changing Area: XXXXXXXXXXXX

Simple lead changes are required, flying lead changes to be penalized. See rules 118 and 124.B.8.

1. Walk at least 15' and jog over log.
2. Transition to lope around end.
3. First line change.
4. Second line change lope around end at arena.
5. First crossing change.
6. Second crossing change.
7. Lope over log.
8. Third crossing change.
9. Fourth crossing change.
10. Lope up center, stop and back.

129. Pattern E – Level II Western Riding

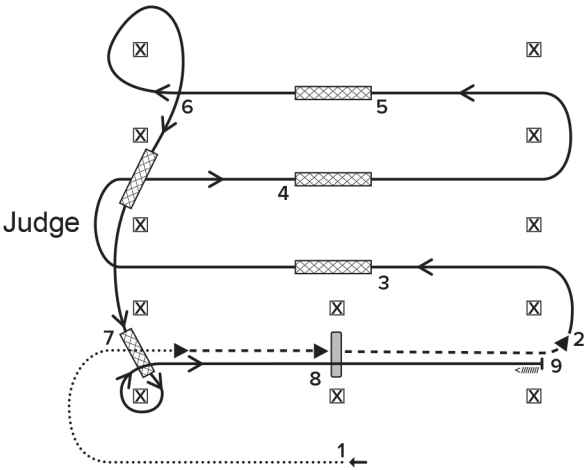

Walk: Lope: _____
 Back: // Jog: - - - - -
 Lead Changing Area: XXXXXXXXXXXX

Simple lead changes are required, flying lead changes to be penalized. See rules 118 and 124.B.8.

1. Walk, transition to jog, jog over log.
2. Transition to lope.
3. First crossing change.
4. Second crossing change.
5. Third crossing change.
6. Circle and first line change.
7. Second line change and circle.
8. Lope over log.
9. Stop and back.

130. Pattern F – Level II Western Riding

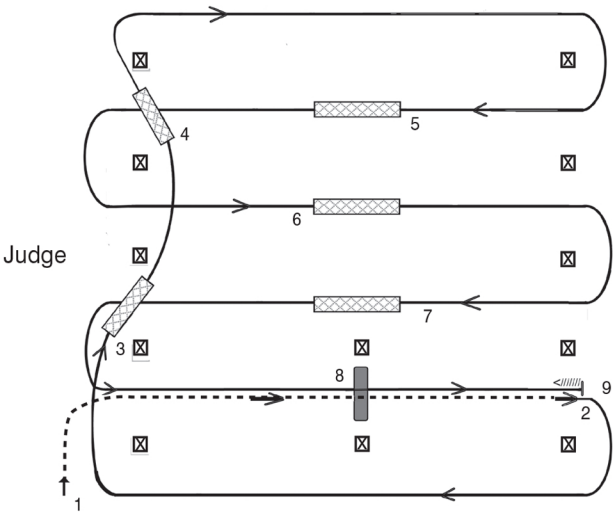

Walk: Lope: _____
 Back: //////////////// Jog: - - - - -
 Lead Changing Area: XXXXXXXXX

Simple lead changes are required, flying lead changes to be penalized. See rules 118 and 124.B.8.

1. Walk, transition to jog, jog over log.
2. Transition to lope around end.
3. First line change.
4. Second line change, lope around end of arena.
5. First crossing change.
6. Second crossing change.
7. Third crossing change.
8. Lope over log.
9. Stop and back.

131. Pattern 1 – Level III and IV Western Riding

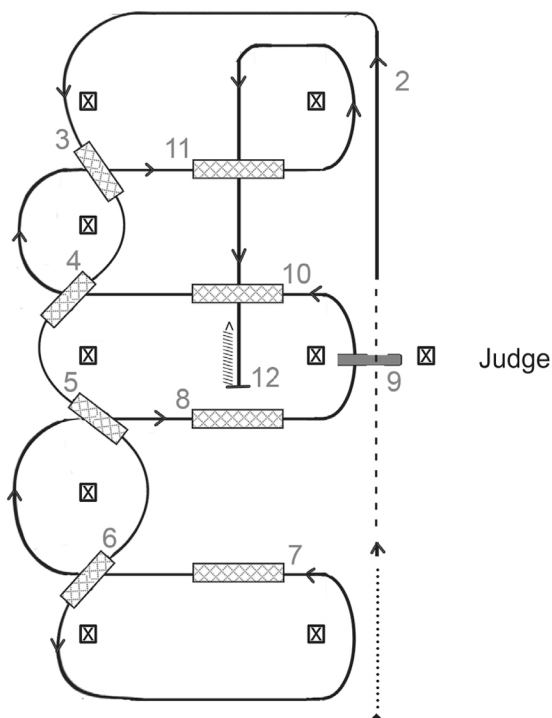

Walk: Lope: _____
 Back: // Jog: - - - - -
 Lead Changing Area: XXXXXXXXXXXX

Flying lead changes are required, simple lead changes to be penalized. See rules 118 and 124.B.9.

1. Walk & jog over log.
2. Transition to lope.
3. First line change.
4. Second line change.
5. Third line change.
6. Fourth line change, lope around the end of arena.
7. First crossing change.
8. Second crossing change.
9. Lope over log.
10. Third crossing change.
11. Fourth crossing change.
12. Lope up center, stop and back

132. Pattern2–Level III and IV Western Riding

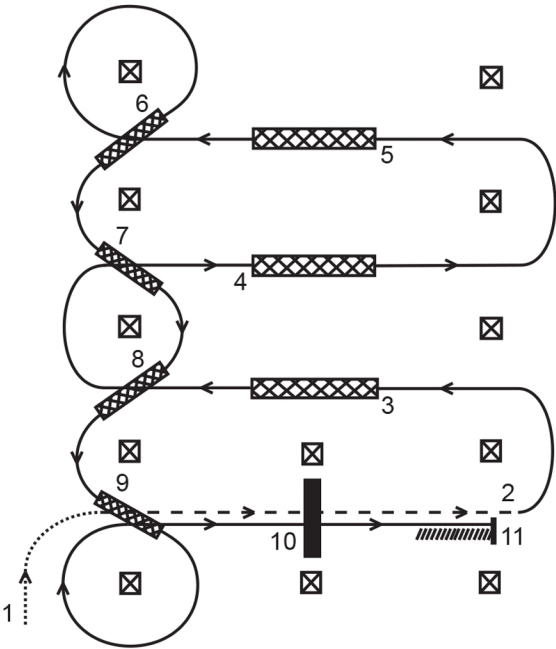

Walk: Lope: _____
 Back: /////////////// Jog: - - - - -
 Lead Changing Area: XXXXXXXXXXXX

Flying lead changes are required, simple lead changes to be penalized. See rules 118 and 124.B.9.

1. Walk, transition to jog, jog over log.
2. Transition to lope.
3. First crossing change.
4. Second crossing change.
5. Third crossing change
6. Circle and first line change.
7. Second line change.
8. Third line change.
9. Fourth line change and circle.
10. Lope over log.
11. Stop and back.

133. Pattern3–Level III and IV WesternRiding

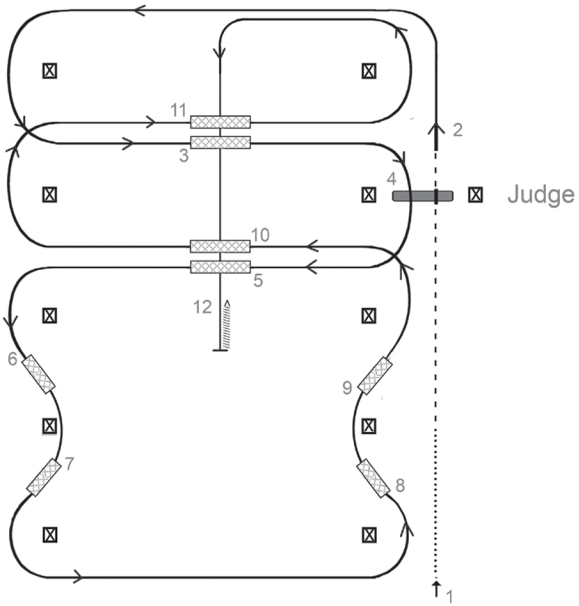

Walk: Lope: _____
 Back: // Jog: - - - - -
 Lead Changing Area: XXXXXXXXXXXX

Flying lead changes are required, simple lead changes to be penalized. See rules 118 and 124.B.9.

1. Walk, transition to jog, jog over log.
2. Transition to lope.
3. First crossing change.
4. Lope over log.
5. Second crossing change.
6. First line change.
7. Second line change.
8. Third line change.
9. Fourth line change.
10. Third crossing change.
11. Fourth crossing change.
12. Lope up the center, stop and back.

134. Pattern4–Level III and IV Western Riding

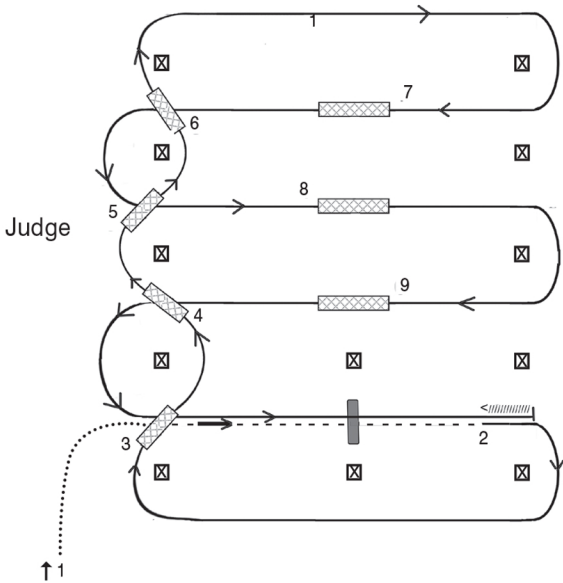

Walk: Lope: _____
 Back: //////////////// Jog: - - - - -
 Lead Changing Area: [XXXXXXXXXX]

Flying lead changes are required, simple lead changes to be penalized. See rules 118 and 124.B.9.

1. Walk, transition to jog, jog over log.
2. Transition to lope.
3. First line change.
4. Second line change.
5. Third line change.
6. Fourth line change.
7. First crossing change.
8. Second crossing change.
9. Third crossing change.
10. Lope over log
11. Stop & back.

135.-149. – NOT ASSIGNED

REINING

General

150. Reining is a class which requires considerable skill on the part of the rider and many hours of training for the horse. It should not be required of inexperienced riders or green horses. A properly executed advanced reining pattern utilizes Advancement Levels III and IV skills.
151. Each contestant will perform the required pattern individually and separately.
152. Judging should stress the skills of the rider in performing the required routine in a light, fluent manner, indicating a composed, harmonious attitude between horse and rider.
153. To rein a horse is not only to guide him, but also to control his every movement. The best reined horse should be willfully guided or controlled with little or no apparent resistance and dictated to completely. Any movement on his own must be considered a lack of control. All deviations from the exact written pattern must be considered a lack of or temporary loss of control, and therefore faulted according to severity of deviation. Credit will be given for smoothness, finesse, attitude, quickness and authority in performing the various maneuvers while using controlled speed.
154. Except for junior horses, 5 years and under, shown with hackamore or snaffle bit, only one hand may be used on the reins and hand must not be changed. When a romal is used, it shall be carried as per rule 58. Romals shall not be used forward of the cinch.

Scoring

155. Scoring will be on the basis of 0 to infinity, with 70 denoting an average performance. Use of the 4-H Reining score card is recommended and may be posted after the conclusion of the class. A scribe may be provided for the judge. Management should encourage the posting of reining score cards as a learning tool for the exhibitors.
156. Contestants will be penalized each time the following occur.
 - A. **No Score (disqualification):** not eligible to place or receive a ribbon.
 1. use of illegal equipment
 2. willful abuse of an animal while in the show arena
 3. using reins or romal as a whip
 - B. **Zero Score:** no placing or ribbon to be awarded.
 1. failure to complete pattern as written
 2. performing the maneuvers other than in specified order
 3. the inclusion of maneuvers not specified, including, but not limited to:
 - a. backing more than two strides (four steps)
 - b. a turn of more than 90 degrees where not specified
 4. equipment failure that delays completion of pattern

5. running away or failing to guide where it becomes impossible to discern whether the entry is on pattern
6. jogging in excess of 1/2 circle or 1/2 the length of the arena while starting a circle, circling or exiting a rollback (except when required in the pattern)
7. overspins of more than 1/4 turn
8. more than one finger between the reins
9. changing hands on reins
10. two hands on reins except with junior horses (5 years or younger) ridden two-handed in a bosal or snaffle bit

Note: In all reining classes, excess rein(s) may be straightened or disentangled anytime during the class, provided the rider's free hand used to straighten or disentangle remains behind the rein hand. Any attempt to alter tension or length of the reins from bridle to rein hand is to be considered use of two hands and a penalty score zero or disqualification will be applied.

11. fall to the ground by horse or rider (see rule 40 and 41)
12. balking or refusal of command
13. When going to and coming out of a rollback in a pattern requiring a run-around, a rollback that crosses the center line.

C. 5 Point Penalties:

1. spurring in front of cinch
2. use of free hand to instill fear or praise
3. holding saddle with free hand
4. blatant disobedience including kicking, biting, bucking and rearing

D. 2 Point Penalties:

1. Failure to go beyond markers on stops and rollbacks
2. Break of gait Note: Simple lead changes are allowed for level I or II riders, no break of gait penalty should be applied during the lead change
3. On walk in patterns, loping prior to reaching the center of the arena and/or failure to stop or walk before executing a lope departure.
4. On run in patterns, failure to be in a lope prior to the first marker
5. Freezing up in spins or rollbacks
6. Jogging beyond two (2) strides but less than one half (1/2) circle or one half (1/2) the length of the arena when starting circle at a jog or exiting rollbacks
7. Flying lead change where a simple lead change is required
8. Simple lead change where a flying lead change is required

E. 1 Point Penalties

1. Starting or performing circles or eights out of lead will be judged as follows: (a) Each time a horse is out of lead, a judge is required to penalize by one (1) point. The penalty for being out of lead is cumulative, and the judge will add one (1) penalty point for each one quarter (1/4) of the circumference of a circle or any part thereof that a horse is out of lead.
2. Deduct one (1) point for over or under spinning up to one quarter (1/4) of a turn. A horse can only be assessed one over or under spin penalty per maneuver.

3. In patterns requiring a run-around, failure to be on the correct lead when rounding the end of the arena will be penalized as follows: (a) From the turn to the half-way position at the end wall: one (1) point (b) Beyond the half-way point to the beginning of the run down: an additional point for a total of two (2) penalty points

F. 1/2 Point Penalties

1. A judge is required to penalize a horse one half (1/2) of a point for a delayed change of lead by one (1) stride where the lead change is required by the pattern description.
 2. Deduct one half (1/2) point for starting circle at a jog or exiting rollbacks at a jog up to two (2) strides.
 3. Deduct one half (1/2) point for over or under spinning up to one eighth (1/8) of a turn. A horse can only be assessed one over or under spin penalty per maneuver.
 4. There will be a one half (1/2) point penalty for failure to remain a minimum of twenty (20) feet from the side of the arena when approaching a stop and/or rollback.
 5. In a pattern requiring a run-around, there will be a one half (1/2) point penalty for failure to remain a minimum of 10 feet from either side of the center of the arena when approaching a stop and/or rollback; for small arenas the distance will be at the judge's discretion.
157. Faults against the horse to be scored accordingly against the maneuvers scores, but not to cause disqualification:
- A. opening mouth excessively when wearing bit
 - B. excessive jawing, opening mouth or head raising on stop
 - C. lack of smooth, straight stop on haunches-bouncing or sideways stop
 - D. refusing to change leads
 - E. anticipating signals
 - F. stumbling
 - G. backing sideways
 - H. knocking over markers
158. Faults against the rider (to be scored accordingly, but not to cause disqualification):
- A. losing stirrup or holding on
 - B. any unnecessary aid given by the rider (such as unnecessary talking, petting, spurring, quirting, jerking of reins, and so forth)
 - C. failure to run circles or figure eights within the markers is not considered a fault depending on arena conditions and size; however, failure to go beyond markers on rollbacks and stops is considered a fault
159. The arena or plot for all patterns should be at least 50' x 100' in size with a larger arena preferred. The judge shall indicate with markers on the arena fence or wall, the length of the pattern; markers within the area of the pattern will not be used.

Patterns and Set-Up

160. County or 4-H Club Shows may use simplified reining patterns at their discretion.
161. Any one of the 4-H patterns illustrated may be used in accordance with the Advancement Level. The pattern to be used will be selected by the judges and/or show management and posted at least one hour prior to the class.
162. It is suggested that 4-H show management hold separate classes for Level I and Level II or for young riders. Judging emphasis should stress the abilities of the rider in riding and handling the horse through the routine. (See patterns A, B, C, D and E).

When levels are mixed and the judge agrees, properly executed flying changes will score higher than simple changes on all patterns. It is the judge's opinion as to when a proper simple change begins to outscore a poorly executed flying change.

When simple changes are required, a flying lead change should be penalized and not be scored higher than a well-executed simple lead change.

163. Horses may walk or jog to the center of arena on walk in patterns. However, they must walk or stop prior to starting pattern.

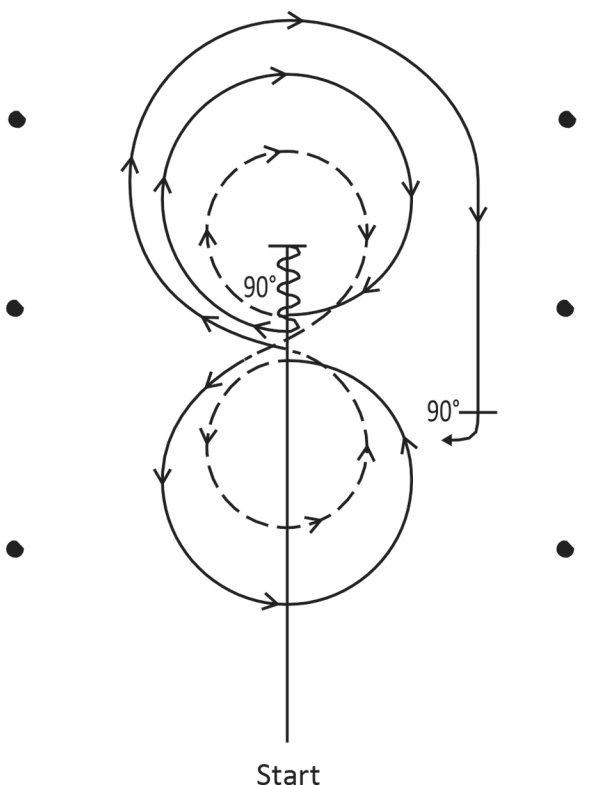

Back:  Jog:  Lope: 

Proper execution of this pattern requires Level I Advancement skills. All stops are balanced.

1. Lope at least ten feet past center marker. Stop & backup to the center, or at least ten feet.
2. 90 degree turn to the left, hesitate.
3. Lope large circle right.
4. Trot small circle right.
5. Lope large circle left.
6. Trot small circle left.
7. At center, pick up right lead, begin a large circle to the right but do not close this circle. Run straight down the right side of the arena staying at least twenty feet from the wall or fence past the center marker, stop.
8. 90 degree turn to the right.

165. PatternB-LevelIReining

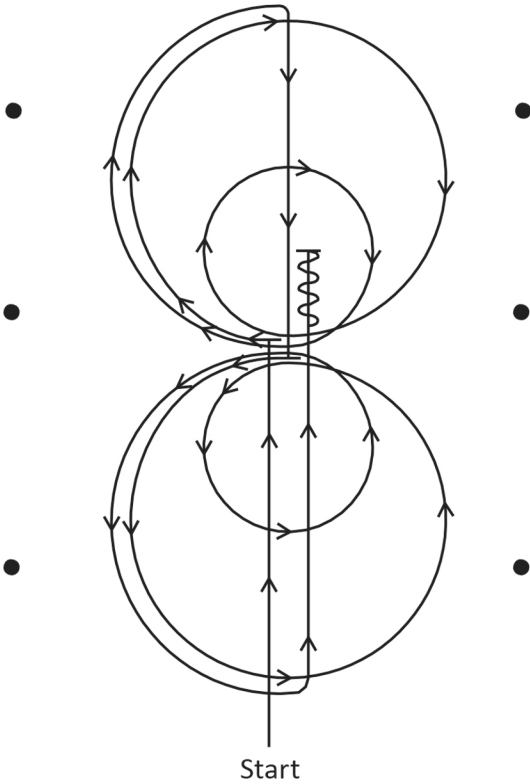

Back:  Jog:  Lope: 

Proper execution of this pattern requires Level I Advancement skills. All stops are balanced.

1. Lope to center of arena and halt at center marker.
2. 90 degree turn to the left.
3. Lope a large circle to the right followed by a small circle to the right.
4. Continue around previous large circle, at the top of the circle, run down the middle to the center marker and halt.
5. 90 degree turn to the right.
6. Lope a large circle to the left followed by a small circle to the left.
7. Continue around previous large circle, at the top of the circle, run down the middle past the center marker, halt and back at least ten feet.

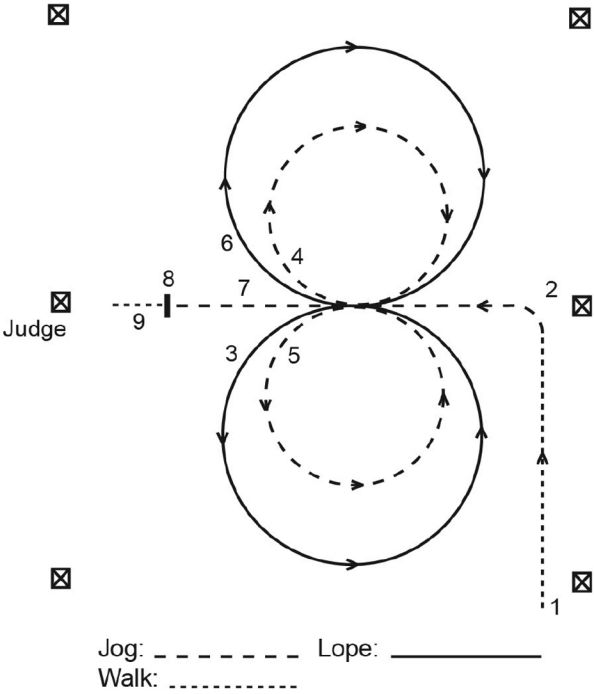

Proper execution of this pattern requires Level I Advancement skills. All stops are balanced.

1. Walk to center marker 20 ft. from fence.
2. Jog to the center.
3. Lope a large circle left at moderate speed.
4. At center, drop to a jog and jog a small circle right.
5. Jog a small circle left.
6. Lope a large circle right at moderate speed.
7. At center, drop to a jog and jog straight 10 ft.
8. Gradual stop through the walk.
9. Walk to Judge for Inspection.

167. Pattern D – Level I Reining

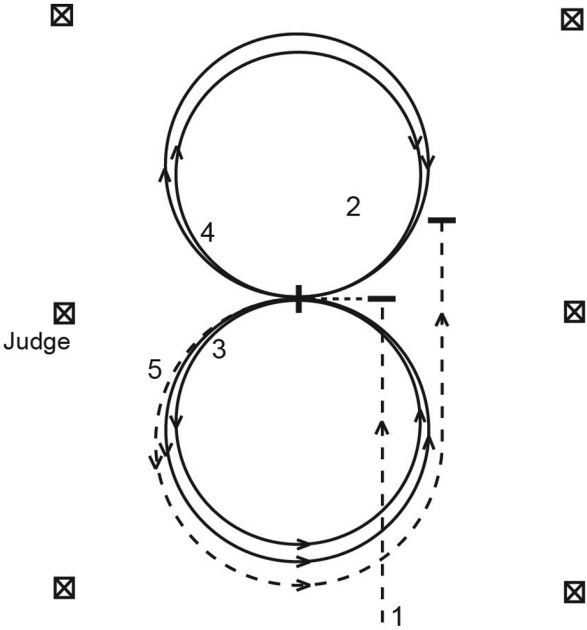

Jog: - - - - - Lope: _____
 Walk:

Proper execution of this pattern requires Level I Advancement skills. All stops are balanced.

1. Jog down the arena to the center marker.
2. Perform a gradual stop. Turn left and walk to center.
3. Lope two circles left of equal size. Gradual stop in the center.
4. Lope two circles right of equal size. Gradual stop in the center.
5. Begin a jog circle to the left but do not close this circle. Jog straight down the side of the arena past the center marker and gradual stop.
6. Walk to Judge for inspection.

168. Pattern E – Level II Reining

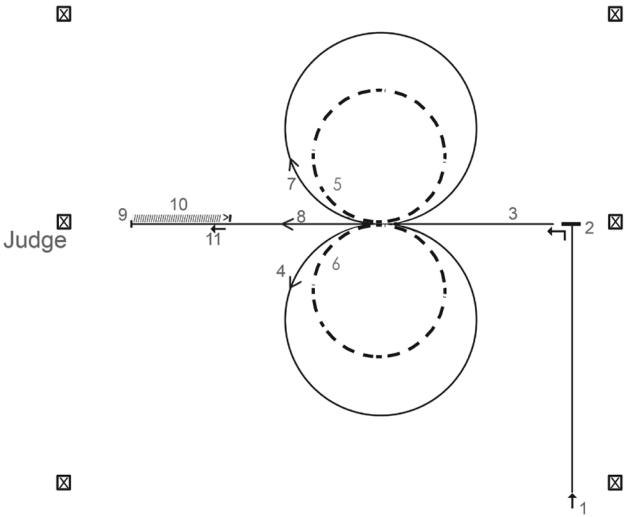

Walk: Lope: _____

Back: // Jog: - - - - -

Proper execution of this pattern requires Level II Advancement skills. All stops are balanced.

1. Lope in a straight line at least 20' from fence.
2. Stop at center marker. Do 90° left hindquarter turn. Hesitate.
- 3-4. Pick up left lead and lope a large circle left at moderate speed.
- 5-6. At center, drop to jog and do a small Figure 8, circle right first.
7. At center pick up right lead and lope a large circle right at moderate speed.
8. Continue straight 10'.
9. Stop.
10. Back.
11. Walk to Judge for inspection.

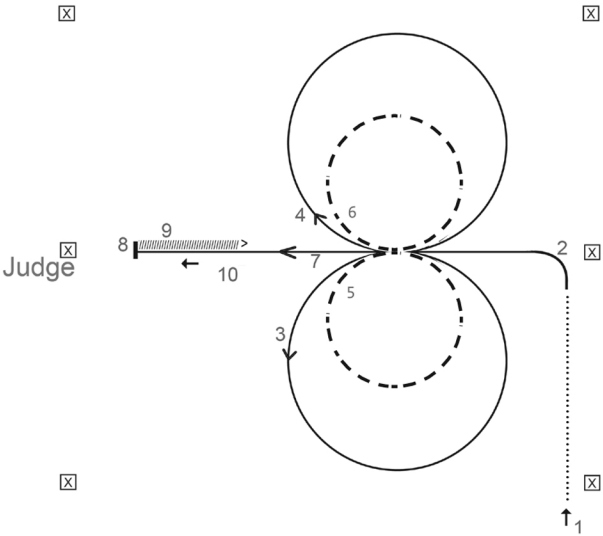

Walk: Lope: _____

Back: // Jog: - - - - -

Proper execution of this pattern requires Level II Advancement skills. All stops are balanced; lead changes are simple.

1. Walk to center marker 20' from fence.
2. Left lead to center.
- 3-4. Lope large Fig. 8 at moderate speed. Left circle first. Simple change.
- 5-6. Jog small Fig. 8 circle left first.
7. At center pick up right lead. Lope straight 10'.
8. Stop.
9. Back.
10. Walk to Judge for inspection.

170. Pattern G – Level II Reining

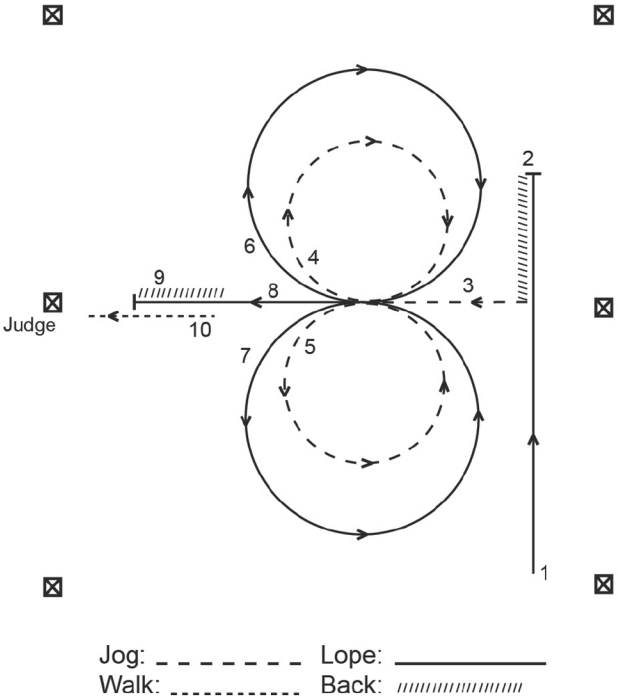

Proper execution of this pattern requires Level II Advancement skills. All stops are balanced; lead changes are simple.

1. Lope in a straight line at least 20 feet from fence.
2. Stop past center marker – back in straight line to center.
3. Hesitate. Turn left 90°. Jog to center.
- 4-5. Jog a small Figure 8 to right first
- 6-7. Lope a larger Figure 8 at moderate speed to right first
8. Continue straight 10'.
9. Stop. Back.
10. Walk to the judge for inspection.

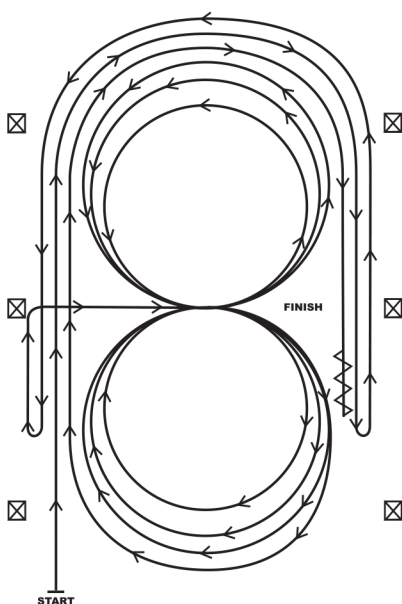

Proper execution of this pattern requires Level II Advancement skills. All stops are balanced; lead changes are simple.

1. Beginning, lope straight up the left side of the arena, circle the top of the arena, and staying at least twenty feet (six meters) from the walls or fence, run straight down the opposite or right side of the arena past the center marker and stop, turn 180 degrees to the left. No hesitation
2. Lope straight up the right side of the arena circle back around the top of the arena, and staying at least twenty feet (six meters) from the walls or fence, run straight down the left side of the arena past the center marker and stop turn 180 degrees to the right. No hesitation
3. Continue up the left side of the arena to the center marker. At the center marker, the horse should be on the right lead. Guide the horse to the center of the arena on the right lead and complete three circles to the right: the first two circles large and fast; the third circle small and slow. Simple change of leads at the center of the arena.
4. Complete three circles to the left: the first two circles large and fast; the third circle small and slow. Simple change leads in the center of the arena.
5. Begin a large circle to the right but do not close this circle. Continue up the left side of the arena, circle the top of the arena, and staying at least twenty feet (six meters) from the walls or fence, run straight down the opposite or right side of the arena past the center marker and do a sliding stop. Backup at least ten feet (three meters). Hesitate.

172. Pattern I - Level II

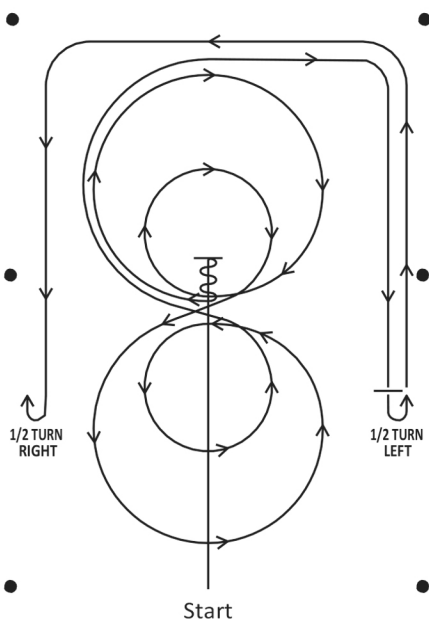

Back:  Jog:  Lope: 

Proper execution of this pattern requires Level II advancement skills. All stops are balanced.

1. Start at end of arena. Run down middle past center marker to a balanced stop.
2. Back at least ten feet to center. 90 degree turn to the left.
3. Pickup right lead, large fast circle, small slow circle.
4. Simple lead change to left, large fast circle, small slow circle.
5. Simple lead change to right, do not close this circle.
6. Run around end of arena and down the side (approximately 20 feet from fence) past center marker and come to a balanced stop.
7. Turn 180 degrees on the haunches to the left.
8. Continue back down side and end of arena to other side (approximately 20 feet from fence) go past center marker and come to a balanced stop.
9. Turn 180 degrees on the haunches to the right. Hesitate to complete pattern.

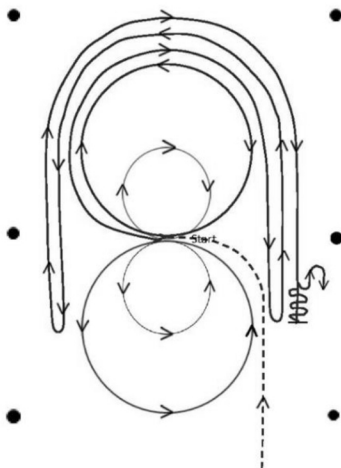

Back:  Jog:  Lope: 

Proper execution of this pattern requires Level II advancement skills. All stops are balanced.

Horses may walk or trot to the center of the arena. Horses must walk or stop prior to starting the pattern. Begin at the center, facing the left wall or fence.

1. Begin on the right lead, complete two circles to the right. The first circle large and fast, the second circle small and slow perform a simple change of leads.
2. Complete two circles to the left. The first circle large and fast, the second small and slow. Perform a simple change of leads.
3. Begin a large fast circle to the right but do not close this circle. Run straight down the right side of the arena staying at least 20 feet from the wall or fence, past the center marker, stop, turn 180 degrees to the left. No hesitation.
4. Lope straight up the right side of the arena circle back around the top of the arena, and staying at least twenty feet from the walls or fence, run straight down the left side of the arena past the center marker and stop, turn 180 degrees to the right. No hesitation.
5. Lope straight up the left side of the arena circle back around the top of the arena and staying at least twenty feet from the walls or fence, run straight down the right side of the arena past the center marker and stop and back at least 10 feet.
6. Turn 180 degrees on the haunches to the left. Hesitate.
7. Turn 180 degrees on the haunches to the right. Hesitate.

174. Pattern K – Level II and III Reining (NRHA Pattern A)

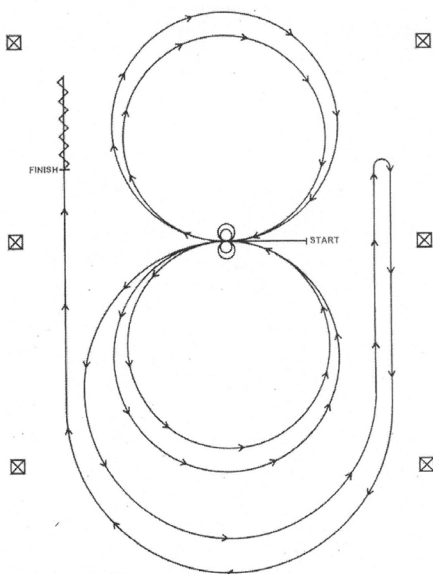

Proper execution of this pattern requires Level II & III advancement skills.

Horses may walk or trot to the center of the arena. Horses must walk or stop prior to starting the pattern. Beginning at the center of the arena facing the left wall or fence.

1. Beginning on the left lead, complete two circles to the left. Stop at the center of the arena. Hesitate.
2. Complete two spins to the left. Hesitate.
3. Beginning on the right lead, complete two circles to the right. Stop at the center of the arena. Hesitate.
4. Complete two spins to the right. Hesitate.
5. Beginning on the left lead, go around the end of the arena, run down the right side of the arena past center marker, stop and roll back right.
6. Continue around the end of the arena to run down the left side of the arena past the center marker. Stop. Backup.

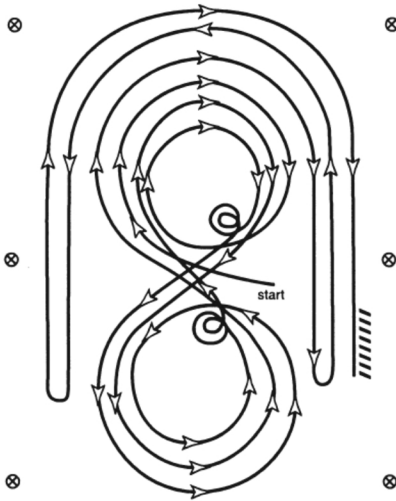

Proper execution of this pattern requires Level III Advancement skills. Flying lead changes are required, simple lead changes to be penalized. Horses may walk or jog to the center of arena. Horses must walk or stop prior to starting the pattern. Beginning at the center of the arena facing the left wall or fence.

1. Starting at the center begin on the right lead, complete two circles to the right the first circle large and fast and the second circle small and slow. Stop at the center of the arena.
2. Complete two spins to the right. Hesitate.
3. Begin on the left lead, complete two circles to the left the first circle large and fast and the second circle small and slow. Stop at the center of the arena.
4. Complete two spins to the left. Hesitate.
5. Take a right lead and make a fast figure eight over the large circles, close the eight, and change leads.
6. Begin a large fast circle to the right but do not close this circle. Run down the right side of the arena past the marker and do a left hindquarter turn at speed, at least 20 feet (6 meters) from the wall or fence—no hesitation.
7. Continue back around the previous circle but do not close this circle. Run down the left side of the arena past the center and do a right hindquarter turn at speed, at least 20 feet (6 meters) from the wall or fence—no hesitation.
8. Continue back around previous circle but do not close this circle. Run down the right side of the arena past the center marker and do a smooth stop at least 20 feet (6 meters) from the wall or fence. Back up at least 10 feet (3 meters). Hesitate to show completion of pattern. Walk to the judge and stop for inspection until dismissed.

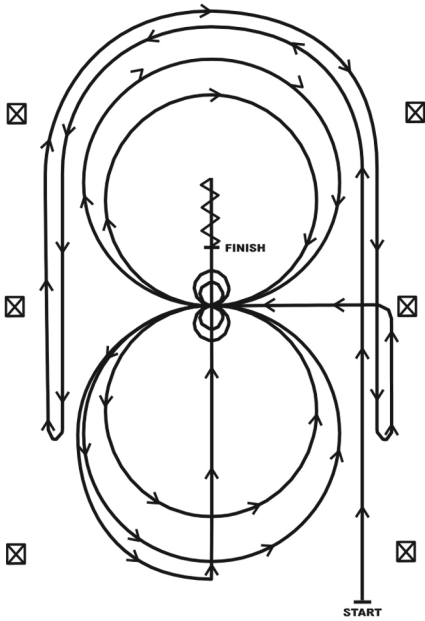

Proper execution of this pattern requires Level III Advancement skills. Flying lead changes are required, simple lead changes to be penalized.

1. Beginning, lope straight up the right side of the arena, circle the top of the arena run straight down the opposite or left side of the arena past the center mark and do a right rollback – no hesitation.
2. Continue straight up the left side of the arena circle back around the top of the arena run straight down the right side of the arena past the center marker and do a left rollback – no hesitation.
3. Continue up the right side of the arena to the center marker, at the center marker the horse should be on the left lead and complete two circles to the left, one large fast and one small slow. Stop at center
4. Complete two spins to the left. Hesitate.
5. Complete two circles to the right, one large fast and one small slow. Stop at center.
6. Complete two spins to the right. Hesitate.
7. Begin a large circle to the left, do not close the circle. Continue up the center of the arena past the center marker and stop.
8. Back up at least ten feet. Hesitate to demonstrate completion of the pattern. Hesitate to demonstrate completion of the pattern.

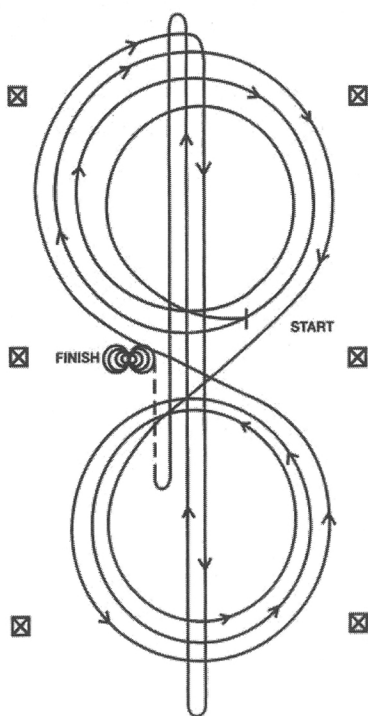

Begin at the center of the arena facing the left wall or wall or fence. Horses may walk or jog to the center of arena on walk in patterns. However, they must walk or stop prior to starting pattern.

1. Beginning on the right lead, complete three circles to the right: the first circle small and slow; the next two circles large and fast. Change leads at the center of the arena.
2. Complete three circles to the left: the first circle small and slow; the next two circles large and fast. Change leads at the center of the arena.
3. Continue around previous circle to the right. At the top of the circle, run down the middle to the far end of the arena past the end marker and do a right rollback – no hesitation.
4. Run up the middle to the opposite end of the arena past the end marker and do a left rollback – no hesitation.
5. Run past the center marker and do a sliding stop. Back up to the center of the arena or at least ten feet. Hesitate.
6. Complete four spins to the right. Hesitate.
7. Complete four spins to the left. Hesitate to demonstration of the pattern.

Rider must drop bridle to the designated judge.

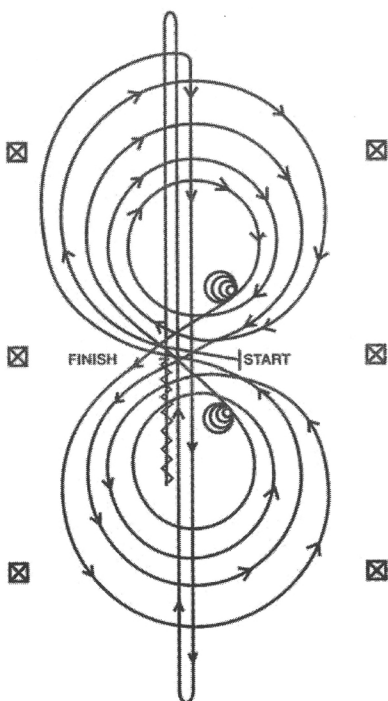

Begin at the center of the arena facing the left wall or wall or fence. Horses may walk or jog to the center of arena on walk in patterns. However, they must walk or stop prior to starting pattern.

1. Beginning on the right lead, complete three circles to the right: the first two circles large and fast; the third circle small and slow. Stop at the center of the arena.
2. Complete four spins to the right. Hesitate.
3. Beginning on the left lead, complete three circles to the left: the first two circles large and fast; the third circle small and slow. Stop at the center of the arena.
4. Complete four spins to the left. Hesitate.
5. Beginning on the right lead, run a large fast circle to the right, change leads at the center of the arena, run a large fast circle to the left, and change leads at the center of the arena.
6. Continue around previous circle to the right. At the top of the circle, run down the middle to the far end of the arena past the end marker and do a right rollback – no hesitation.
7. Run to the middle to the opposite end of the arena past the end marker and do a left rollback – no hesitation.
8. Run past the center marker and do a sliding stop. Back up to the center of the arena or at least ten feet. Hesitate to demonstrate completion of the pattern.

Rider must drop bridle to the designated judge.

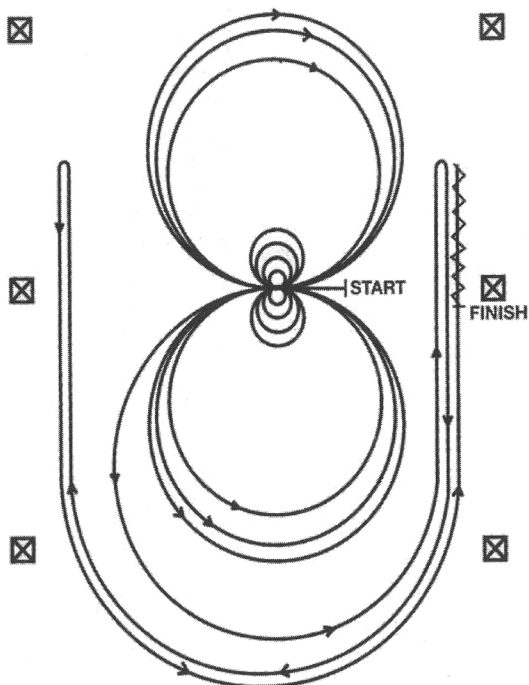

Begin at the center of the arena facing the left wall or wall or fence. Horses may walk or jog to the center of arena on walk in patterns. However, they must walk or stop prior to starting pattern.

1. Complete four spins to the right. Hesitate.
2. Complete four spins to the left. Hesitate.
3. Beginning on the left lead, complete three circles to the left: the first two circles large and fast; the third circle small and slow. Change leads at the center of the arena.
4. Complete three circles to the right: the first two circles large and fast; the third circle small and slow. Change leads at the center of the arena.
5. Begin a large fast circle to the left but do not close this circle. Run up the right side of the arena past the center marker and do a right rollback at least twenty feet from the wall or fence—no hesitation.
6. Continue back around previous circle but do not close this circle. Run up the left side of the arena past the center marker and do a left rollback at least twenty feet from the wall or fence – no hesitation.
7. Continue back around previous circle but do not close this circle. Run up the right side of the arena past the center marker and do a sliding stop at least twenty feet from the wall or fence. Back up at least ten feet. Hesitate to demonstrate the completion of the pattern.

Rider must drop bridle to the designated judge.

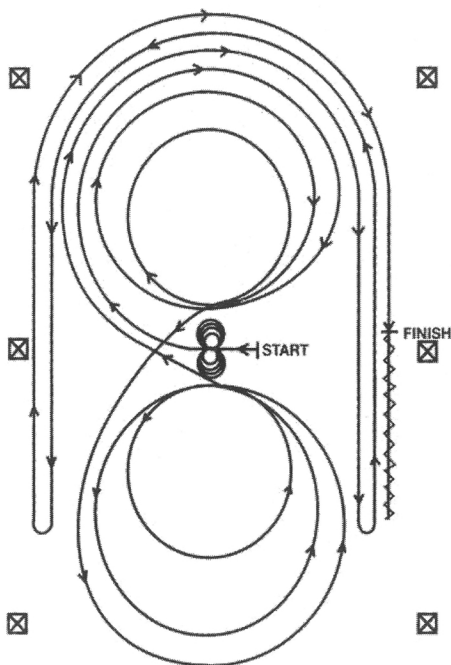

Beginning at the center of the arena facing the left wall or fence. Horses may walk or jog to the center of arena on walk in patterns. However, they must walk or stop prior to starting pattern.

1. Complete four spins to the left. Hesitate.
2. Complete four spins to the right. Hesitate.
3. Beginning on the right lead, complete three circles to the right: the first circle large and fast; the second circle small and slow; the third circle large and fast. Change leads at the center of the arena.
4. Complete three circles to the left: the first circle large and fast; the second circle small and slow; the third circle large and fast. Change leads at the center of the arena.
5. Begin a large fast circle to the right but do not close this circle. Run straight down the right side of the arena past the center marker and do a left rollback at least twenty feet from the wall or fence—no hesitation.
6. Continue back around the previous circle but do not close this circle. Run down the left side of the arena past the center marker and do a right rollback at least twenty feet from the wall or fence—no hesitation.
7. Continue back around the previous circle but do not close this circle. Run down the right side of the arena past the center marker and do a sliding stop at least twenty feet from the wall or fence. Back up at least ten feet. Hesitate to demonstrate completion of the pattern.

Rider must drop bridle to the designated judge.

183.-199. – NOT ASSIGNED

WESTERN DRESSAGE

200. The goal of Western Dressage is to develop a partnership: a happy equine athlete working in harmony with his rider. A system of progressive training produces a horse that is physically strong, balanced, supple, and flexible. Rider and horse achieve this goal using the principles of classical dressage training, combined with the maneuvers of the stock horse, emphasizing the lightness and harmony with the rider.
201. Rider must follow attire and equipment rules as currently published by the Western Dressage Association of America (WDAA)
202. Western Dressage level will be based on a rider's level in Western. A standard Western Dressage score sheet shall be provided for each rider. A scribe shall be provided for the judge. It is suggested that show management use WDAA tests which demonstrate skills corresponding to the level of the participants as follows:

4-H Level I – Basic Level, Test 4

4-H Level II – Level 1, Test 2

4-H Level III – Level 2, Test 3

4-H Level IV – Level 3, Test 4

To download tests, go to

www.westerndressageassociation.org.

SCORING:

10----Excellent

9-----Very good

8-----Good

7-----Fairly good

6-----Satisfactory

5-----Marginal

4-----Insufficient

3-----Fairly bad

2-----Bad

1-----Very bad

0-----Not performed

203. Western Dressage test collective marks:

ALL LEVELS

Gaits: the freedom and regularity of the horse's movement

Impulsion: the horse's desire to move forward, elasticity of steps, roundness

Submission: the horse's attention and confidence, harmony with rider, lightness of movements, and acceptance of the bit

Rider's position and seat: correctness and effect of the aids

- 204.-209. – NOT ASSIGNED

WESTERN DRESSAGE ARENAS

Large Arena: 20x60 meters



Small Arena: 20x40 meters

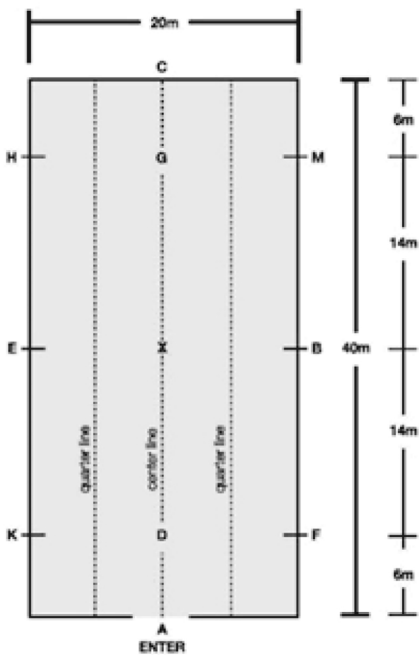

TRAIL DIVISION

Western and English

210. Trail classes may be offered for Western or English but are not to be combined. The two styles are distinctly different and should not compete against each other at any time.
211. This class will be judged on the performance of the horse over obstacles, with emphasis on manners, response to the rider and quality of movement. Credit will be given to horses negotiating the obstacles with style and promptness providing correctness is not sacrificed. Horses should receive credit for showing attentiveness to the obstacles and the capability of picking their own way through the course when obstacles warrant. They should work obstacles cleanly, smoothly and alertly with prompt and willing responses to the rider's cues.
212. Horses shall be penalized for any unnecessary delay while approaching or negotiating the obstacles.
213. Horses must not be required to work on the rail. The course must be designed, however, to require each horse to show the three gaits (walk, jog, and lope) somewhere between obstacles as a part of the course (Exception: Walk/ Trot Trail). Quality of movement and cadence should be considered as part of the maneuver score. While on the line of travel between obstacles, the horse shall be balanced, carrying his head and neck in a relaxed, natural position. The head should not be carried behind the vertical, giving the appearance of intimidation, or be excessively nosed out, giving a resistant appearance. Gaits between obstacles shall be designated on the posted course.
214. The course to be used should be posted at least one hour before the scheduled starting time of the class.
215. Appointments and Tack
 - A. Western Trail – refer to Definitions and Descriptions as well as the Western Division (see rules 90 and 91).
 - B. English Trail – refer to Definitions and Descriptions as well as the English Division, Hunt Seat (see rules 400-405).
 - C. Ranch Trail- refer to Ranch Horse Division. (page 94).

Scoring

216. All horses shall begin with a score of 70, denoting an average performance. Obstacle scores are to be determined and assessed independently of penalty points. It is possible for a horse to receive a negative score. The use of the trail scoring sheet is recommended and may be posted after the conclusion of the class. A scribe may be provided for a judge who wishes to use the following scoring system.

217. Each obstacle will receive an obstacle score that should be added or subtracted from 70. Each obstacle will be scored on the following basis, ranging from plus 1 and 1/2 to minus 1 and 1/2. In addition, any penalty scores accrued at an obstacle are to be subtracted from each obstacle score:

-1¹/₂ extremely poor
-1 very poor
-1/2 poor
0 correct
+1/2 good
+1 very good
+1¹/₂ excellent

218. Penalties should be assessed per occurrence as follows:

A. Disqualifications (should not be placed):

1. Loss of control of the horse
2. Illegal equipment or illegal use of hands on reins
3. Fall by horse or exhibitor (pg. 7 rule 40 and 41)
4. Abuse of horse

B. Zero Scores: scores of 0 are not to be placed; (In Ranch Trail) scores are considered Off patterns (OP): OP's are to be placed below horses performing all maneuvers.

1. Use of more than one finger between reins.
Exception: does not apply to English Trail.
2. Use of two hands. Exception: in English Trail or with junior horses ridden in a snaffle bit or hackamore, where the use of two hands is required. Changing hands to work an obstacle is permissible; otherwise only one hand is permitted on the reins.
3. Use of romal other than as outlined. (pg. 12 rule 58)
4. Failure to work an obstacle in any manner, other than how it is posted on the course. Failure to work an obstacle either by skipping, not attempting or after attempting it and having three (3) refusals or when deemed necessary by the judge, the judge will ask the contestant to proceed to the next obstacle. Third cumulative refusal, balk, or evading an obstacle by shying or backing. This includes dropping a rope gate.
5. Performing obstacles other than in the specified order including failure to enter, exit or work the obstacle from the correct side or direction. Including overturns of more than 1/4 turn.
6. Riding outside designated boundary.
7. Equipment failure that delays completion of pattern
8. Excessive schooling, pulling, turning, stepping or backing anywhere on course.
9. Failure to ever demonstrate the correct lead and/or gait as designated.
10. failure to dally and remain dallied during the drag in ranch trail.

C. 5 Point Penalties

1. Dropping slicker or object required to be carried on course
2. Use of either hand to instill fear or praise
3. Stepping outside the confines of, falling, or jumping off of or out of an obstacle with more than one foot
4. Holding saddle with either hand
5. Blatant disobedience (kicking out, bucking, rearing, striking)

6. Horse misses/evades an element/component of an obstacle that is part of a series with more than one foot.
7. Each refusal is a 5 pt penalty. Refusals are cumulative. Refusals are defined as: Any action taken by the horse to avoid performing an obstacle, part of a combination of obstacles or portion of a trail course. (See 218.B.4. page 68)
These actions may include, but are not limited to the following:
 - a. **Balking:** (Any action that results in a horse blatantly and continuously refusing a rider's command).
 - b. Attempting to evade an obstacle to be negotiated by shying, backing more than 2 strides away or running past the obstacle.
 - c. Any blatant action by the horse that demonstrates an unwillingness to approach, negotiate and/or complete an obstacle.
8. Each complete loss of the gate. If a rope gate is used, and the exhibitor loses control of the rope gate, for safety reasons the exhibitor should not attempt to pick up the rope again. The exhibitor is given a 15 point penalty, for an obstacle that has not been attempted/completed, and the exhibitor is expected to proceed to the next obstacle. (See 218.B.4. page 68)

D. 3 Point Penalties

1. Incorrect or break of gait at walk or jog for more than 2 strides
2. Out of lead or break of gait at lope (except when correcting an incorrect lead)
3. Knocking down an elevated pole, cone, barrel, plant obstacle, or severely disturbing an obstacle.
4. Stepping outside the confines of, falling, or jumping off of or out of an obstacle with one foot
5. Missing or evading a pole in a series of obstacles with one foot
6. Taking more than two steps when asked to ground tie

E. 1 Point Penalties

1. Each major hit of or stepping on a log, pole, cone or an element of an obstacle
2. Incorrect gait at walk or jog for two strides or less
3. Both front or hind feet in a single-strided slot or space
4. Skipping over or failing to step into a required space
5. Splitting the pole in a lope-over
6. Failure to meet the correct strides on trot over and lope over log obstacles, if specified
7. 1 to 2 steps on mount/dismount or ground tie except shifting to balance

Note: Light ticks on logs/obstacles can be counted against the maneuver score.

Obstacle Set-Up

219. Management, when setting courses, should keep in mind that the idea is not to trap a horse, or eliminate it by making an obstacle too difficult. All courses and obstacles are to be constructed with safety in mind. When courses are set, junior trail and lower level trail courses should be less difficult. When the distances and spaces are measured between all obstacles, the inside base to inside base measurement of each obstacle considering the normal path of the horse, should be the measuring point. Enough space must be provided for a horse to jog [at least 30 feet (9 meters)] and lope [at least 50 feet (15 meters)] for the judges to evaluate these gaits.
220. If disrupted, the course shall be reset after each horse has worked. In cases where a combination of obstacles are used, the course cannot be reset until the contestant finishes the entire course, regardless of where any disruption occurs.
221. **OBSTACLE REQUIREMENTS.** Course will include a minimum of 6 and maximum of 10 obstacles. The judge has the right to alter the course.

A. **Walk-overs.** An obstacle of a least four poles set as follows:

On the ground: 20 inches (50.8cm) to 24 inches (60.96cm) between poles.

Elevated: 22 inches (55.9cm) to 24 inches (60.96cm) raised with a maximum center height of 10 inches (25.4cm).

Maybe set in a straight line, curved or zigzag pattern or in increments of the above stated distances.

B. **Trot/Jog-overs.**

Western Jog-overs: 3' to 3'6" between poles or multiples of that.

English Trot-overs: 3'6" to 4' between poles. 4' is preferred for English.

Elevated: Maximum center height of 10 inches (25.4cm).

Maybe set in a straight line, curved or zigzag pattern or in increments of the above stated distances.

C. **Lope/Canter-overs.**

Western Lope-overs: 6' to 6'6" between poles.

English Canter-overs: 6' to 8' between poles. 8' is preferred for English.

Elevated: Maximum center height of 10 inches (25.4cm)

Maybe set in a straight line, curved or zigzag pattern or in increments of the above stated distances.

***Note:** A curved or zigzag design is measured for distance between the poles, from center of the length of the pole to the center of the length of the next pole.

- D. **Side-pass.** An object of sufficient length and which is safe may be used to demonstrate the responsiveness of the horse to leg signals. If raised, height may not exceed 12 inches (30.48cm). The obstacle may be designed to require the horse to side pass either or both ways or in a pattern. Objects such as a bale of hay, or other objects that may become entangled in a horse's feet or legs will not be used.

Sample sidepass obstacle

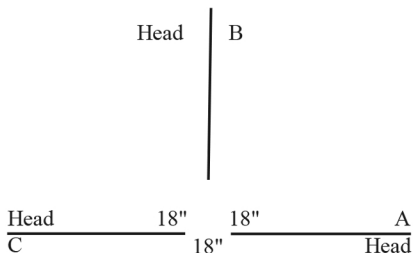

- E. **Lime (or flour) Circle.** Requiring either:
1. Turn on the forehand with front feet inside and back feet turning on outside of circle; or
 2. Turn on the haunches with hind feet inside and front feet on outside of circle.
- F. **Square (box), minimum 6' (1.82m) sides.** Ride into the square. While all four feet are confined in the square, make a 360 degree turn and ride out.
- G. **Gate.** The gate must be set up so that it is a minimum of 6 feet (1.83m) in length and 4 feet (1.21m) in height and so that the exhibitor can open from his right or left side. It is permissible to change hands prior to opening gate, if the gate is in such a position as to justify the change of hands on thereins. Riders losing control of the gate while passing through shall be penalized and scored accordingly.
- H. **Back through.** Shall consist of either:
1. **Poles.** Straight L, double L, V, U or similar shaped obstacle.
Set on the ground: Minimum of 30 inches (76.2cm) between poles
Elevated: Minimum of 32 inches (81.28cm) between poles. Elevated height not to exceed 12 inches (30.48cm).
 2. **Barrels or Cones.** Minimum of three. Minimum of 36 inches (91.44cm) between barrels or cones.
 3. **Triangle.** Minimum of 36 inches (91.44cm) between at entry and 40 inches (101.6cm) between for sides. If guardrails are used with b. or c. they shall be 3 to 4 feet (.91m-1.21m) from the sides of the obstacle.
- I. **Bridge.** A bridge with a wooden floor not to exceed 12 inches (30.48cm) in height with or without side rails. Side rails to be placed not less than 36 inches (91.44cm) apart (walk over only).

- J. **Water Hazard.** A ditch or shallow pond of water may be used. A horse must pass through this obstacle, which must be large enough so that to properly complete this obstacle all four feet of the horse must step in the water. Management may not place any item in the water. If a box is used, simulated water is permissible. If the water box is used preceding and in combination with a bridge, simulated water must be used.
- K. **Carrying Object.** Any object, other than another animal or fowl, and of a reasonable size or weight, may be carried to a specific point.
- L. **Slicker.** When this obstacle is used, it will be so located that the exhibitor can ride to the slicker, put it on and remove it and return it to a designated place. Reins may be held or dropped on the neck of the horse or over the saddle horn while so doing.
- M. **Mailbox.** Remove and/or replace items. Side pass is optional.
- N. **Ground Tie.** Ride or proceed to the designated place, dismount and either hobble or ground tie the horse and move away from the horse a reasonable distance to clearly show the proper training of the horse. If a ground tie is required, a mounting block should be provided.

To ground tie, reins shall be as follows.

1. Split: drop the reins.
 2. Romal: remove reins over head of horse, unclip off rein and drop or leave romal rein in place and hobble or use a get down rope.
 3. Hackamore or Bosal: drop mecate/lead.
 4. Snaffle with mecate rein: drop the lead.
- O. **Serpentine.** Obstacle consisting of four pylons, guardrails optional, through which a horse will maneuver at a walk or jog-trot.
 Walk pylons, minimum of 3 feet (.91m) apart, base to base
 Jog-trot pylons, minimum of 6 feet (1.82m) apart, base to base
 Guardrails shall consist of poles or similar objects placed parallel and at a minimum of 3 feet (.91m) from the side of pylons
- P. **Jog-around.** Square consisting of four poles, minimum 12 feet (3.65m) long, and a pylon placed in the center of the square. Exhibitor will enter over a designated pole, perform a minimum 90 degree jog around the pylon and exit over the designated pole.

Q. **Jog-through.** Shall consist of poles. L, double L, V, U or similar shaped obstacle.

On the ground: 3 feet (.91m) minimum and 4 feet (1.21m) maximum

Elevated, 3 feet 3 inches (.99m) minimum and 4 feet 3 inches (1.29m) maximum.

Elevated height shall not exceed 12 inches (30.48cm).

R. A jump may be used, providing it does not exceed 18" in height.

S. Any other safe and negotiable obstacle which could reasonably be expected to be encountered on a trail ride and meets the approval of the judge may be used.

T. A combination of two or more of any obstacle is acceptable.

222. **Unacceptable obstacles:**

A. Tires

B. Live animals

C. Hides

D. PVC pipe

E. Rocking or moving bridges

F. Water box with floating or moving parts

G. Flames, dry ice, fire extinguisher, etc.

H. Logs or poles elevated in a manner that permits them to roll

I. Plastic sheets or tarps that are stepped on

223. The judge should walk the course and has the right and duty to alter the course as necessary. The judge may remove or change any obstacle he deems unsafe or non-negotiable and has the duty to do so. If, at any time, a trail obstacle is deemed to be unsafe by the judge, it shall be repaired or removed from the course. If an obstacle is damaged and it cannot be repaired and horses have completed the course, the score for that obstacle shall be deducted from all previous works for that class.

224. Judges should be encouraged to walk the course with exhibitors, prior to the beginning of the trail class and to respond to questions of clarification, regarding the course.

225. The trail course designer should be available to the trail arena during the trail classes.

226. Management should encourage the posting of the judge's trail score sheets as a learning tool for the exhibitors.

227.-234. – NOT ASSIGNED

GYMKHANA DIVISION

235. Gymkhana games, defined as athletics on horseback, can be traced to nearly as early as domestication of horses. The games are a test of equitation and teamwork between horse and rider. Not only will participation in the games create more effective horsemanship, it will create enthusiasm. Participants, judges and leaders should remember all gymkhana games can be dangerous. Adhering to given guidelines and following good equitation will allow for enjoyable competition while assuring safety.

General Rules and Regulations Governing Gymkhana Events

236. Equipment: Western equipment is to be used.
- A. In timed events, western-type equipment must be used. Use of a hackamore (including mechanical hackamores) or other types of bridles or bits is the optional choice of the contestant; however, the judge or show official may prohibit the use of bits or equipment he/she may consider severe. Riders should check with show officials regarding any equipment which may be considered unconventional.
1. Required Equipment:
 - a. ASTM/SEI approved safety helmet with harness securely fastened. A certified equestrian helmet with safety harness fastened in place is required in gymkhana events, activities and practice sessions (i.e., timed events not involving livestock). It is the responsibility of the parent or guardian of the 4-H member to see that the headgear worn complies with such standards and is in good condition.
 2. Optional Equipment:
 - a. tie-downs
 - b. whips or bats
 - c. skid, splint, or bell boots
 - d. roping or closed reins
 3. Prohibited Equipment:
 - a. jerk lines
 - b. tack collars
 - c. draw reins
 - d. any attachment between the foot and the stirrup including rubber bands
237. Dress (see #90). Safety helmets and Western attire are required. Ball caps are prohibited.
238. Pattern
- A. Lime or flour may be used for marking lines (e.g., keyhole race).
 - B. Altering distances may be necessary to make individual arenas safe.

- C. Pylons make excellent markers, if needed.
- D. Barrels may be made of rubber, plastic or steel, with both ends in place.
- E. Games may be canceled due to poor arena footing at the discretion of the judge or safety steward.

239. Reruns

- A. Reruns will be made at the end of the event.
- B. A rerun may be awarded for failure of timing devices or timers, obstruction of the course as determined by the judge, or breakage of arena equipment if it interferes with a run.
- C. The manner in which ties are settled is a management decision. They may be left as a tie or run off.
- D. The use of two stopwatches, with at least 1/100 second breaks, are recommended. The official time shall be the average of two times, if electronic timers are used a backup watch should be used.
- E. The show management should make every attempt to secure knowledgeable judges.

240. Safety

- A. Appointment of a safety steward is recommended to ensure safe games' equipment, properly fitted tack and safe riding apparel.
- B. At no time shall horses and riders be TIED OR SECURED TOGETHER, or a rider tied or secured to any part of the saddle in any manner including rubber bands.
- C. It is required that all events be held inside a closed arena. During all runs, arena gates will be closed. Failure to enter and leave the arena, mounted, at a walk or jog results in a disqualification, unless the class dictates the rider dismounts as part of the class such as described in rules 255, 256, 260 and 264.
- D. Only the participating contestant, arena crew and officials are allowed in the arena. Sitting on arena fences is not permitted. Courses may be changed or moved, if ground conditions dictate, but the course must remain the same for all contestants in any given class.
- E. If using 5-gallon buckets for an event, remove handles to prevent contestants from catching their hands in them.
- F. Appointment of a gatekeeper is encouraged.

241. Disqualifications (not to be placed)

Listed are general disqualifications. For other disqualifications, check the specific events.

- A. Leaving the course or breaking the pattern (shall include the performance of any maneuver not included in the pattern).

- B. If the horse is out of control before or during the run including, but not limited to, kicking, biting, bucking, rearing and striking while in the arena (including entering and exiting the gate.)
 - C. If the contestant uses unsportsmanlike conduct in the arena (including profane language, disorderly conduct or an unmanageable horse).
 - D. If the contestant abuses the horse (including excessive jerking of the reins, striking the horse with the games' equipment, spurs, bats, crops, whips and so forth).
 - E. Use of spurs, reins, whips, ropes or bats forward of the cinch.
 - F. Return across the start-finish line before finishing the pattern.
 - G. Immobility or lack of forward progression that exceeds 30 seconds for those events that do not require dismounting. In clarification, this means that once the gate is open and the arena is cleared of obstructions, the contestant has 30 seconds to cross the start lines.
 - H. If rider or horse falls (see general rules, rule 40 pg. 6).
242. Gymkhana division rules apply from the time of entry to the time of exit (gate to gate) for every rider.
- 243.-244. – NOT ASSIGNED

INDIVIDUAL EVENTS

Barrel Race

245. Three barrels shall be placed 75 feet apart in a triangle formation (see diagram). The rider will cross start line, ride to #1 barrel, circle it to the right, ride to #2 barre, circle it to the left, ride to #3 barrel, circle it to the left and ride across the finish line, passing between barrels #1 and #2. OR, the rider will cross start line and ride to #2 barrel, circle it to the left, ride to #1 barrel, circle it to the right, ride to #3 barrel, circle it to the right, and ride across the finish line, passing between #1 and #2.

A. Disqualifications:

1. violating general rules;
2. not crossing finish line between barrels #1 and #2.

B. Penalty:

A 5-second penalty will be assessed for each barrel knocked over. Contestants are allowed to touch barrels with hands.

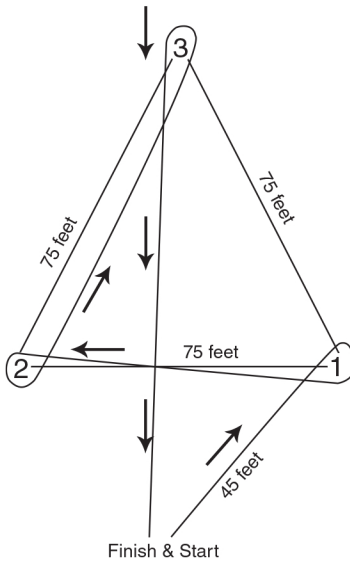

Barrel Race Pattern

C. Barrel Race Pattern

Suggest a minimum of 18' from fence for barrel number 1 & 2, 36' for barrel 3. In a large arena, a maximum of 90' x 110' barrel spacing, 45' from starting line to 1st barrel. A minimum of 75' to a maximum of 105' is allowed for stopping. In smaller arenas, the space between barrels and fences may not be less than 18'; however, the pattern may be shortened by 6' or a multiple of 6' on all sides.

Clover Leaf

246. Place one cone in the center with four barrels each 30 to 45 ft. from the center cone in a plus sign design. Pattern can be completed with all right or all left turns. To make all left turns, start to the right of #4 barrel. Turn left around center cone to #1 barrel. Turn left around #1 barrel to center cone. Turn left around center cone to #2 barrel. Turn left around #2 barrel to center cone. Turn left around center cone to #3 barrel. Turn left around #3 barrel to center cone. Turn left around center cone to #4 barrel. Finish to the right of #4 barrel. To make all right turns, start to the left of #4 cone and continue in the same pattern always turning right at each barrel and cone.

Left Turns

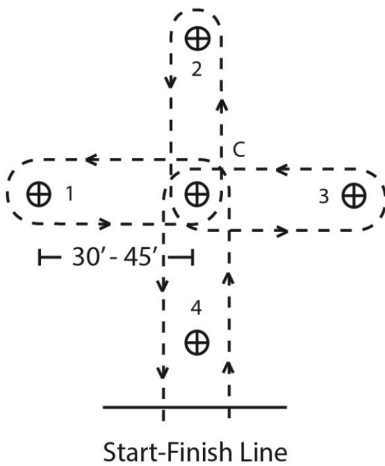

Right Turns

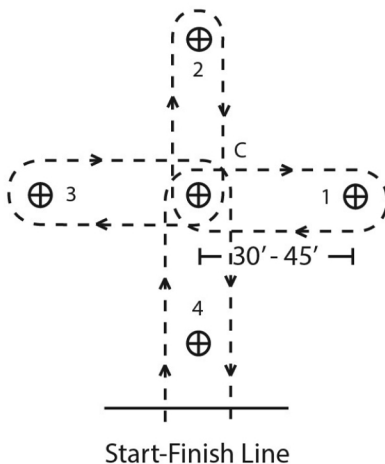

A. Penalties:

1. 5-second penalty for each cone knocked over
- B. This pattern is ideal for Beginners and Level 1 riders interested in barrels. It emphasizes correct leads when going into turns.

Slalom Cones

247. Six cones shall be staggered 25 ft. apart. Rider will start at a trot to the left of #1 cone, turning right, then turn left around #2 cone, turn right around #3 cone, turn left around #4 cone, and turn right around #5 cone. Rider will trot left around #6 cone. On the way back, rider will make a full circle around each cone in reverse order, #5 cone, #4 cone, etc. Rider must work this pattern at a trot.

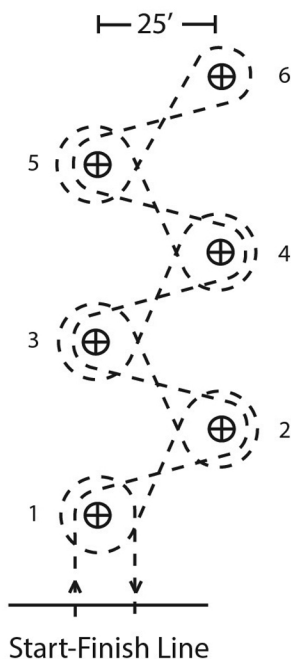

A. Penalties:

1. 3-second penalty for each break of gait
 2. 5-second penalty for each cone knocked over
- B. This pattern is ideal for Beginners and Level 1 riders interested in poles, barrels or ranch horse. It emphasizes the use of right and left hand to guide their horse. It also requires maintaining control and forward motion.

Flag Race

248. Option 1 – Two containers (preferably 55-gallon drums), will be placed 100 feet apart, if arena permits, and 100 feet from the start-finish line. A 5-gallon bucket filled with appropriate material should be placed on top of each drum.
- The rider starts with one flag in hand and deposits it in container A, proceeds to container B, removes the flag from container B and rides to the finish line.
 - OR, the rider starts with flag in one hand and places the flag in container B and removes the flag from container A and proceeds to the finish line.
 - Another version: A rider starts without flag, picks up flag at first barrel and deposits flag in bucket on second barrel and proceeds across finish line.

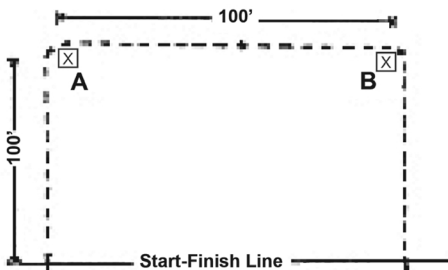

249. Option 2 – Three barrel course.

- A rider crosses the starting line, picks up a flag at the first barrel, makes the turn outside the end barrel, deposits flag in container on third barrel and rides across the finish line.
- Another version: Rider crosses the starting line with a flag in hand, deposits it in bucket on first barrel, circles end barrel, picks up a flag from the container on third barrel and crosses the finish line with a flag.
- Both versions can be run to the right or left.

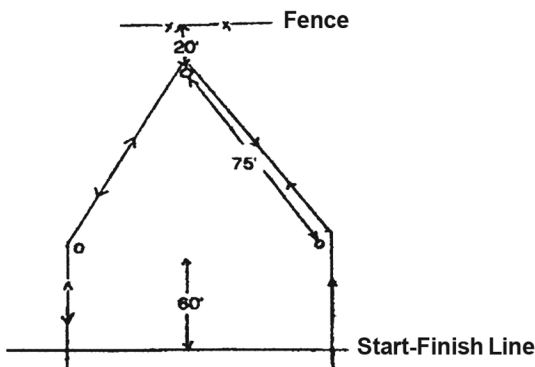

250. Option 3—Seventy five up and back.

- A. A rider crosses starting line with flag, races to barrel, turns at the barrel and sticks the flag into the bucket sitting on the barrel. Rider then continues on and crosses finish line. Can be run on right or left.

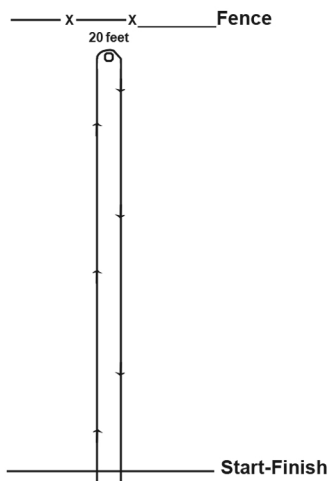

251. Flag Race Disqualifications:

- A. violating general rules;
- B. flag not remaining in container;
- C. rider missed picking up flag or planting flag on first attempt;
- D. rider circling the barrel or backing;
- E. knocking over a 5-gallon bucket or barrel or both;
- F. failure to maintain prescribed course of travel as outlined in the pattern.

Pole Bending

252. Six poles should be spaced 21 feet apart with the first pole set 21 feet from the start-finish line (see diagram). The rider crosses start-line, rides to either side of pole #6 to the left or right and then weaves (bends) around the opposite side of each pole to pole #1, turns around pole #1 and weaves (bends) around the opposite side of each pole to pole #6, turns around pole #6 and rides across finish line. Contestants will not be disqualified for stopping forward motion unless it exceeds 30 seconds.

- A. Disqualifications:
- 1. violating general rules;
 - 2. riding across start-finish line when circling pole #1;
 - 3. breaking pattern.

- B. Penalty – 5-second penalty assessed for each pole knocked over.

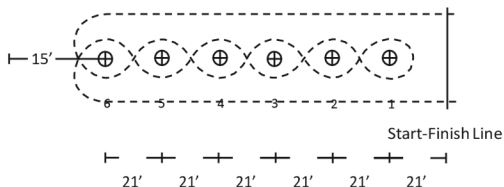

Keyhole Race

253. Option 1 – Chalk Keyhole Race

- A. The course will be drawn with chalk as diagramed below. The rider crosses the start line, rides in through the 6' opening into the circle, turns the horse around either direction, then rides back out the opening and across the finish line.

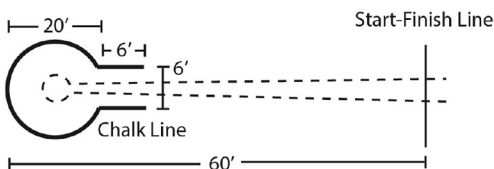

- B. Disqualifications:

1. violating general rules
2. not crossing the finish line between markers
3. stepping on or out of the keyhole chalk line

254. Option 2 – Pole Keyhole Race

- A. The course is as diagramed below. The rider crosses the

start line, rides through the four standing poles, turns the horse around either direction then rides back through the four standing poles and across the finish line. One or more assistants shall be stationed by the poles, to place the poles upright and/or to rake the disturbed area near the poles, as needed.

- B. Disqualifications:

1. violating general rules;
2. not crossing finish line between markers;
3. starting or stepping on or over back line.

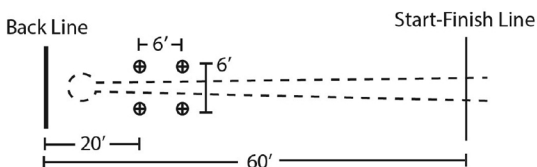

- C. Penalty – 5-second penalty assessed for each pole knocked over.

Potato Race

255. A potato is placed at the far end of the arena, either on the ground or on a barrel. The rider must ride across the start-finish line to the potato, pick up the potato and carry it back across the start-finish line. If the potato is dropped, the rider must stop and retrieve it.

Ride and Lead

256. The rider crosses the start-finish line and rides past a pylon marker at the far end of the arena, dismounts past the pylon, and leads the horse back to the start-finish line.
Disqualification for violating general rules.

Figure 8 Stake Races

257. Option 1

- A. The course shall be laid out with two poles, 100 feet apart, and labeled pole #1 and #2. The start-finish line will be 15 feet from pole #1 (see diagram).
- B. The rider must cross the start-finish line, ride around pole #2 to the left, continue to pole #1, around pole #1 to the right, back to pole #2, around pole #2 to the left and return to the start-finish line.
- C. 5 second penalty for knocking over obstacles.

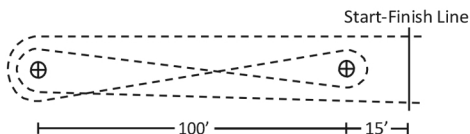

258. Option 2

- A. The course shall be laid out with two poles 120 feet apart labeled pole #1 and pole #2. The pylons 30 feet apart, and 60 feet from either poles #1 and #2, will be the start-finish line (see diagram).
- B. The rider must cross the start-finish line and ride to pole #1, turning around pole #1 to the left, ride to pole #2, turning around pole #2 to the right and return to the start-finish line.
- C. There is a 5 second penalty for knocking over poles.

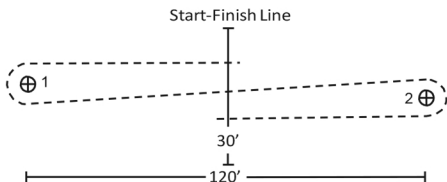

259. Disqualifications for both options:

- A. violating general rules.

- B. circling pole.
- C. knocking over cones, start / finish pylon.

Boot, Candy Bar, Cracker, Pop or Dress Race

260. These are all variations of the same event. For safety, the management should provide attendants for the horses during the activities listed below. The rider rides across the start-finish line and does one of the following:
- A. dismounts, puts on own boots (from a pile), mounts and returns to finish line;
 - B. dismounts, eats a candy bar, mounts and returns to finish line;
 - C. dismounts, drinks a can/cup of pop, mounts and returns to finish line;
 - D. dismounts, eats crackers, whistles, mounts and returns to finish line;
 - E. dismounts, puts on clothes provided, mounts and returns to finish line;
 - F. dismounts, crawls through barrel, mounts and returns to finish line.
261. Disqualifications in Boot, Candy Bar, Cracker, Pop or Dress race:
- A. violating general rules;
 - B. in options B, C and D, rider must eat or drink entire food or beverage.

Walk, Trot or Gallop Race

262. The course shall be laid out with two pylon markers, 100 feet apart, labeled #1 and #2. The start line shall be at marker #1, the finish line at marker #2. The rider must walk to marker #2, turn and trot back to marker #1, turn, and gallop back to the finish line. Each time the horse breaks gait, the rider must return to the marker and start that gait over again.

Disqualifications for violating general rules.

Egg Race

263. The rider crosses the start-finish line and rides to the far end of the arena, picks up an egg in a spoon and rides to the start-finish line.

Disqualifications:

1. violating general rules;
2. touching the egg with hands;
3. dropping the egg;
4. holding spoon more than halfway up the handle;
5. using gum or sticky substance on the spoon or egg.

Musical Mounting

264. This event is to be ridden as a class with any number of riders. Allow plenty of room for the class.
- A. The riders ride while music is being played. As soon as the music stops, the riders dismount, move to the off side of the horse and remount. The last rider to remount is excused from the arena. The last rider remaining wins. Gait will be determined by the judge.
 - B. Disqualifications:
 - 1. violating general rules;
 - 2. incorrect gait at any point during the class.
265. Another version includes use of feed sacks for riders to stand in when the music stops. There should be one less sack than riders. One sack is removed as music starts and riders mount.

Dollar Bill Contest

266. This class is to be ridden at the walk, trot, lope and hand gallop, at the direction of the judge. The rider is to place a dollar bill between his or her leg and the horse.
- A. Last person to drop their dollar bill wins
 - B. Chaps and shorts are prohibited
 - C. Disqualification:
 - 1. violating general rules;
 - 2. using sticky substances between the rider and dollar bill;
 - 3. touching the dollar with your hand;
 - 4. not obeying commands.

Egg and Spoon Contest

267. Rider carries a spoon with an egg while performing basic horsemanship commands walk, trot, lope and stop.
- A. Last person to drop the egg from spoon wins.
 - B. Disqualifications:
 - 1. violating general rules;
 - 2. touching the egg with hands;
 - 3. dropping the egg;
 - 4. holding spoon more than halfway up the handle;
 - 5. using gum or sticky substance on the spoon or egg;
 - 6. not obeying commands.

TEAM/GROUP EVENTS

Double barrels

268. Two riders, each holding onto one end of a 6 foot length of breakable tape, run a regular barrel race pattern. Tape to be furnished by management.

A. Disqualifications:

1. violating general rules;
2. either partner losing one end of tape;
3. breaking the tape.

B. A 5-second penalty for each barrel knocked over.

269. –NOT ASSIGNED

STOCK HORSE DIVISION

General

270. Dress (see #90)
271. Equipment (see #236) – exception is rule #236.A.1. A helmet is recommended but not required in Working Western.

Heading and Heeling

272. General – AQHA Rules/score Sheets are to be used.
- A. A rider shall be allowed to show in Heading, Heeling or both.
 - B. All heading and heeling cattle shall be protected by horn wraps. Cattle may be assigned by draw or cattle may be chute-run and working order will be drawn.
 - C. The roper may throw only two loops. If more than one loop is thrown, rider must recoil the rope before rebuilding the additional loop. If the roper fails to catch with two loops, he will retire from the arena. After two minutes, with or without two loops, the ride is completed and the rider must retire from the arena.
 - D. If a roper drops his rope, he will receive no score.
 - E. Rider is to stay mounted.
 - F. The run is complete when both ropes are dallied and tight with horses in facing position. Time is not a judging factor.
 - G. The rope must be wrapped around the saddle horn at least one complete turn before it is considered a dally.
 - H. Horses must start from the roping box. Must start from behind a barrier (an electronic barrier is acceptable).
 - I. Only the horse's performance, including manners behind the barrier and at all other times, is to be judged.
 - J. The judge may at his/her discretion award new cattle to enable contestant to show his/her horse's ability on the cow including:
 - 1. The cow won't run or stops
 - 2. Chute or barrier malfunctions
 - 3. Cow turns back immediately
 - 4. Cow leaves arena
 - K. LEGAL CATCHES. Whether being judged or not, legal catches are required by both the header and heeler. Any figure-eight, front leg, or the tip of a horn is not a legal heading catch. A tail only is not a legal heeling catch.
273. Heading Rules
- A. Legal catches in heading are both horns, half-head and around the neck. Any figure-eight catch or front leg in the catch is not legal.

- B. Show management may assign a competent adult or youth to assist headers with facing. If the heeler misses, the header will not be faulted (receive the -3 score) for not facing.
- C. The heading horse will be judged on four different maneuvers: Box and barrier running and rating Setting and handling Facing.

274. Heeling Rules

- A. A legal catch in heeling is defined as a catch that holds from behind the steer's shoulders and back, around the flank, or on one or both heels, but not by the tail only.
- B. For heeling, a head loop must be placed on the steer's head or horns before the animal leaves the chute. Show management may assign a competent adult or youth to assist the competitor who is heeling.
- C. The heeling horse will be judged on four different maneuvers: Box Run and rate Position Stopping

275. Scoring

- A. Scoring will be on the basis of 0-100, with 70 denoting an average performance. Each maneuver will be scored from a plus three (3) to a minus three (3), in 1/2 point increments.
- B. Maneuvers judged are as follows:
 - 1. Correct Handling in the Box
 - a. Ready to enter the box
 - b. Set horse
 - c. Coils on right side & flat
 - d. Rope tail on left
 - e. Proper spoke on loop
 - f. Aware of partner
 - g. Steer ready when called for
 - h. Breaking the barrier is a 5-point penalty
 - 2. Tracking Cattle
 - a. Scoring steer (barrier) – heading only
 - b. Tracking in position
 - c. Aggressiveness
 - 3. Rope Swing
 - a. In control of loop
 - b. Build loop
 - c. Flat swing
 - 4. Delivery of Throw
 - a. Proper loop size
 - b. Timing
 - c. Follow through
 - 5. Catch
 - a. Legal head or two leg heel (+3)
 - b. One leg heel (0)
 - c. No catch (-3)

6. Dally & Handle
 - a. Pull slack correctly
 - b. Dally with thumb up
 - c. Control of horse

7. Facing
 - a. Dallied/Facing and pulled tight (+3)
 - b. Facing with slack in rope (0)
 - c. No face (-3)

C. Faults and Disqualifications

1. Any unnecessary whipping, jerking reins, talking or any noise making, slapping, jerking rope or any unnecessary action to induce the horse to perform better, will be considered a fault and scored accordingly.
2. The contestant shall not attempt to rope the animal until the barrier flag has been dropped. Any attempt by a contestant to position his horse behind the barrier enabling the contestant to rope the animal without attempting to leave the box shall be disqualified.
3. Intentional and continuous stretching of the steer after the horses have faced.
4. Failure to maintain a dally through the completion of the run.

D. Penalties. A heading horse will be penalized as follows:

1. Two(2)points—freeze up in the box (refusing to move), jumping the barrier, setting up or scotching, ducking off, failure to face completely, freeze up while facing.
2. Three (3) points – additional loop on either end.
3. Five(5)points—refusing to enter the box, rearing up in box, broken barrier, running into the steer, refusing to pull, blatant disobedience including kicking, biting, bucking, rearing and striking.

E. Penalties. A heeling horse will be penalized as follows:

1. Two (2) points – header breaking the barrier.
2. Three (3) points – additional loop on either end.
3. Five(5)points—refusing to enter the box, rearing up in box, assuming position on the wrong side of the steer, running into the steer, failure to stop on hindquarters and hold position through the completion of the run, blatant disobedience including kicking, biting, bucking, rearing and striking.

Breakaway Roping

276. General:

- A. This is a timed event with a 30-second time limit.
- B. Contestant must start from behind a barrier. A 10-second penalty will be added to the time for breaking the barrier. Score line shall be 6 to 10 feet depending on arena size.
- C. A contestant may use two loops, if two are carried, within the time limit. Contestant may not build a loop in the arena. One or two ropes are to be tied to the saddle horn by a heavy string, provided by show management, in such a manner as to allow the rope to be released from the horn when the calf reaches the end of the rope. Tie string within 6 inches of the end of the rope. A visible cloth or flag must be attached to the end of the rope tied to the horn to make it easier for the flagger to see it break free.
- D. The contestant shall receive a no time should he break the rope from the horn by hand or touch the rope or string after the catch is made. If the rope dallys or will not break free when the calf reaches the end of it, the contestant will receive a no time.
- E. Time will be called from drop of flag at barrier to the break of the rope string from the saddle horn. A legal catch is to be any loop that goes completely over the calf's head and draws up on any part of the calf's body, causing the rope to break away from the saddle horn. Roping the calf without releasing the loop from the hand is not permitted.
- F. The rope may not pass through the bridle, tie-down, neck rope or any other device.
- G. The contestant shall not attempt to rope the animal until the barrier flag has been dropped. Any attempt by a contestant to position his horse behind the barrier enabling the contestant to rope the animal without attempting to leave the box shall be disqualified.

Steer or Calf Daubing

277. General:

- A. 30-second time limit.
- B. Cattle and a roping box with barrier are required for this event.
- C. The rider backs into the heading box with a 4-foot daubing stick (see diagram) dipped in paint. The rider signals readiness for the steer and rides after the steer upon its release. The rider must leave paint on the steer, in back of the shoulder, then raise the stick to call for time. Score line shall be 6 to 10 feet depending on arena size.

278. Disqualifications:

- A. violating general rules.
- B. daubing the steer at any point in front of the shoulder.

279. A 10-second penalty will be assessed for breaking the barrier.

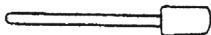

Daubing Stick

4' Round Broom Handle

Cloth Wrapped Around Broom
Handle and Secured

Goat Tying/Goat Tail Tying

280. General:

- A. Two officials are required for this event.
- B. The goat is staked or held on a 10-foot rope at the far end of the arena. The rider rides to the goat, dismounts and ties any three legs (for younger members, tie a ribbon on the tail). The rider then raises hands to signify time and backs away from the goat. Tie must stay intact for 6 seconds.
- C. The goat should be released at the same time for each contestant. Time of goats release to be determined by management.

281. Disqualifications:

- A. not allowing daylight under goat before throwing and tying;
- B. violating general rules;
- C. horse crossing the rope or hitting the goat.

Team Penning

282. General:

- A. It is strongly recommended that roping cattle not be used.
- B. Within a 2-minute time limit, three riders must cut out from the herd and pen three head of cattle with the assigned (same) identity number. The fastest time wins.
- C. A team may call for time with only one or two assigned cattle penned. However, teams penning three cattle place higher than two, and two higher than one, regardless of time.
- D. All cattle will be bunched on the cattle side of the starting line before time begins. A flag man will raise a flag to signal when arena is ready. Contestants will be given their cattle penning number upon crossing the start line. Riders are committed once they enter the arena. Time begins when ANY rider crosses the starting line.
- E. To call for time, one rider and only one must ride into the gate and raise a hand for the flag. The flag will drop when the nose of the horse enters the gate and the rider calls for time. It is the judge's ruling that the horse must not enter the pen past its tail or the team will take a no time. This is to prevent abuse and damage to the cattle.

- F. A warning may be given to the team working, telling them they have 30 seconds left.
- G. Contestants are expected to quietly return cattle to the herd following completion of the run.

283. Set Up

- A. There should be two timers and two flaggers. One flagger is positioned at starting line to flag when time begins, and one positioned at the pen opening to flag when time stops.
- B. The open end of the pen shall be 75 percent of the distance from the cattle wall to the opposite end of the arena. The starting line shall be 60 percent of the same distance. The pen shall be 16 feet from the arena fence, with the following specifications: the wing and back panels shall be 16 feet in length. The depth of the pen must be a minimum of 16 to a maximum of 24 feet, at the option of the committee. The wing side of pen shall consist of an 8-foot panel with a 10-foot opening. See drawing for details.

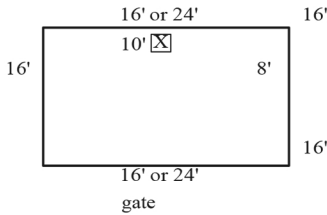

- C. The starting line is marked by suitable markers both sides of the arena. An actual line is not drawn on the arena since this spooks some cattle and horses.

284. Disqualifications/No Time

- A. Contact with cattle by hand, hats, ropes, bats, romals or any other equipment
- B. Exhibiting any unnecessary roughness or roping of cattle
- C. Hazing with whips or ropes
- D. Calling for time with any wrong-numbered cattle in the pen
- E. More than five head of cattle brought across the starting line
- F. All undesignatated cattle must be on the cattle side of the starting line when the team calls for the time or the team will be automatically disqualified. If a team calls for time with only one or two of their cattle in the pen, the remainder of their designated cattle DO NOT have to be on the cattle side of the starting line.
- G. Examples of unnecessary roughness which will result in disqualification are:
 1. Jumping cattle or making them leave the arena;
 2. Excessive bumping, biting or stepping on the cattle by a horse;

3. Rider forces a cow to slam into the arena fence;
4. Cattle bumping at the entrance to the pen;
5. Slamming cattle into the back panel of the pen;
6. Hitting cows broadside; and
7. Knocking a cow down

285.-299. – NOT ASSIGNED

RANCH HORSE DIVISION

300. Tack and Attire

- A. Saddle shall be of a western roping type, with a double rigging and equipped with a cinch hobble. Exception: A center fire rigging may have a single rig. Horn shall be wrapped and designed for roping, either rubber wrapped or with an additional leather wrap. Saddle blanket(s) or pad(s) must be used and shall be in good condition and of a size to protect the horse while doing ranch work. A breast collar is highly recommended.
- B. Bridles. Snaffles must have browband type bridles. Curb and spade bits may have one-ear, split ear, or browband type bridles. Bosals and/or Jaquimas may have a fiador or simple hanger. Bosalitas may have a simple hanger or a thong tied to the forelock. All bridles must be humane and in good repair.
- C. Reins – may be split, romal or mecate sufficiently long to allow the horse to walk on a draped rein.
- D. There are no horse's age restrictions for types of bits or bridles used, however all chosen equipment must be used correctly. Snaffles and bosals must be ridden two handed (with the exception of while using a rope or any other task requiring the use of a free hand), curb/leverage bits must be ridden one handed, a two rein outfit must be ridden one handed. Refer to rules 58, 59, 60, and 61.
- E. Attire – Rider shall wear western style clothing that is well fitted and work-like in appearance. Shirts must be long sleeved, full length (chest and midriff covered), long pants, western riding boots, belt, and cowboy hat (helmet). Optional attire: gloves, ties, chaps, chinks, vests, jackets, raincoat or scarf, safety helmet with harness.
- F. Rope, Lariat or Riata – The riders must have and carry a rope, lariat or riata, at least 30' and no more than 70' in length, attached to their saddle for all classes that require roping, in a manner that the rope is accessible while mounted and does not interfere with the saddle horn or rider. For classes providing a rope to drag a log, the rider should not have a rope tied to their saddle. The rope, lariat or riata used may be nylon, polyester, rawhide or leather. Hondas may be nylon, polyester, rawhide, leather, metal or breakaway styles.
- G. Grooming- This is the ideal however horses that are shown in other Western or English Divisions should not be penalized for any of these items.
 - 1. No hoof polish, or hoof black.
 - 2. No braided or banded manes/tails or tail extensions.
 - 3. Trimming inside ears is discouraged.
 - 4. Trimming bridle path, fetlocks and/or excessive (long) facial hair is allowed.

Note: Equipment with silver should not count over a good working outfit. Excessive silver on bridles and saddles is discouraged.

H. Optional Equipment

1. Hobbles
2. Spurs
3. Chaps or chinks
4. Skid, splint or bell boots
5. Safety helmet (a helmet is encouraged and shall not be discriminated against)
6. Get down rope
7. Breast collar

I. Prohibited Equipment

1. Tie downs
2. Loop (roping) reins
3. Tack collars
4. Jerk Lines
5. Whips or bats
6. Mechanical hackamores
7. Gag bits
8. The judge may prohibit the use of any equipment deemed too severe or inhumane.

301. General

- A. Any horse with open sores or bleeding apparently caused by tack, equipment or rough handling shall be eliminated from competition and shall not be placed.
- B. Score sheets may be posted or made available for review by the contestants. Management should encourage the posting of the judge's score sheets as a learning tool for the exhibitors.

302. **In all cattle classes, a zero score will be assessed for abuse, which includes running the cow into the fence.**

303.-304. – NOT ASSIGNED

RANCH HORSEMANSHIP

General

305. The purpose of this class is to show a horse and rider's ability to work together in the requested gaits and maneuvers. Riders will be asked to perform a designated pattern. Riders may be asked to mount, dismount, walk, jog, lope and lengthen any of these gaits.
306. Rider will be judged on hands, basic position, position in motion and designated class procedures.
- A. Hands –
1. Upper arms to be in a straight line with body; the arm holding the reins is bent at the elbow. Reins will be held per equipment requirement (curb reins in one hand, snaffle or bosal reins held in two hands), hand position should not be changed during the performance except when necessary to perform a task (roping, open a gate). Reins are to be carried immediately above or in front of and as near to the saddle horn as possible. When riding with one hand the rider's hand should not move further than six inches to either side of the horse's neck. The free hand is held at the waist or neatly down on the rider's leg.
 2. See rule 58 for guidelines on split rein use.
 3. See rule 59 for guidelines on romal use.
 4. See Rule 60 for guidelines on snaffle bits.
- B. Basic position –
1. Rider should sit in the saddle with knees slightly bent and weight distributed over the balls of the feet. Stirrups should be adjusted to allow the boot heel to be lower than the toe.
 2. The upper body position is perpendicular to the horse not leaning off to the side. When in the roping position, the body should be bent forward slightly at the waist without changing the position of the legs. The body should appear comfortable and relaxed at all times.
- C. Position in Motion – All movements by the horse should be governed by the use of imperceptible aids. The rider should not be in front of or behind the movement of the horse. Exaggerated body, hand or leg movement will be considered a fault. The rider should sit the jog but may post (without concern to diagonal) or stand when asked to lengthen the trot. A rider moving opposed to the horse's movement will be penalized.

307. Tack and Attire (see #300)
308. Performance of horse – The horse should be in balance at all times, working off its haunches with its head held in a natural position with alert ears and moving at a natural pace. A working ranch horse should work on a relatively loose rein with light contact and without requiring undue restraint. The horse should be responsive to the rider and make all required transitions smoothly, timely and correctly.

Scoring

309. Judges should use the 4-H Ranch Horsemanship Score card. Exhibitors are to be scored from 0 to 100, with 70 denoting an average performance. Patterns will be divided into 6 to 10 maneuvers, as specified by the judge, and each maneuver will be scored from plus 3 to minus 3 with 1/2 point increments acceptable that will be added or subtracted from 70. Maneuver scores should be determined independent of penalties, and should reflect equal consideration of both performance of the exhibitor's pattern and the horsemanship form and effectiveness of the exhibitor to result in the following scores: +3 Excellent, +2 Very Good, +1 Good, 0 Average or Correct, -1 Poor, -2 Very Poor, -3 Extremely Poor. Exhibitors overall horsemanship form and effectiveness should also be scored from 0 to 5 with 0 to 2 Average, 3 Good, 4 Very Good, 5 Excellent.

Penalties

310. Maneuver evaluations and penalty applications are to be determined independently. The following penalties will be applied for each occurrence and will be deducted from the final score:

A. Minor One (1) Point Penalties:

1. Break of gait at the walk/trot or wrong lead up to 2 strides
2. Over or under turn 1/8 of designated turn
3. Over cueing with reins and/or legs
4. Reins too long/short or uneven
5. Failure of horse to stand still at end of pattern
6. Obviously looking for lead
7. Tick or hit of cone
8. When asked to ground tie taking 2 or less steps

B. Major Three (3) Point Penalties:

1. Not performing the specific gait or not stopping within 10 feet (3 meters) of designated location
2. Incorrect lead for more than 2 strides
3. Break of gait at the lope (except when correcting an incorrect lead)
4. Break of gait at walk or trot for more than 2 strides
5. Over or under turn from 1/8 to 1/4 turn
6. Taking more than 2 steps when asked to ground tie

C. Severe Five (5) Point Penalties:

1. Blatant disobedience including kicking, pawing, bucking, and rearing
2. Loss of stirrup or rein
3. Touching the horse or saddle
4. Cueing with the end of the romal
5. Spurring in front of the cinch

D. Zero Scores (Eligible for placing but not above anyone receiving a score above zero):

1. Off pattern
2. Wrong side of cone or knocking over cone
3. Failure to perform or achieve the specified gait or lead
4. Over/under turn more than 1/4 turn

E. Disqualifications (should not be placed):

1. Loss of control of the horse
2. Illegal Equipment or illegal use of hands on reins (See rule 300.D. Page 94)
3. Fall by horse or exhibitor (pg. 7 rules 40 and 41)
4. Abuse of horse or schooling

Class Routine

311. The Ranch Horsemanship class runs individual patterns without the rail work.
312. Pattern skills may be chosen from those listed. Patterns may be chosen from those provided in this rule book or created by the show management or judge.

A. Level I patterns may include:

1. walk, jog or lope over ground poles
2. lope on correct lead
3. gradual stop from any gait

B. Level II patterns may include any Level I skills and the following:

1. rein back over 10' in a straight line
2. walk or jog a serpentine or figure eight
3. perform a simple lead change
4. build a loop, mounted, and swing, at a halt, walk or jog
5. demonstrate the ability to extend or lengthen all gaits
6. Balanced stop from any gait

C. Level III patterns may include any level I and II skills and the following:

1. side pass
2. 90°, 180° or 360° turn on hindquarter or forehand
3. dismount and remount
4. flying change of lead on a large serpentine (more than 60' apart) or on straightaway
5. build a loop and swing it at the lope
6. dismount – unbridle and rebridle horse

D. Level IV patterns may include any level I, II, and III skills and the following:

1. sliding stop
2. roll back
3. spins
4. flying changes in a short serpentine (changes less than 60' apart) or on straight away
5. two tracking right or left at jog or lope

313. Pattern A – Level I Ranch Horsemanship

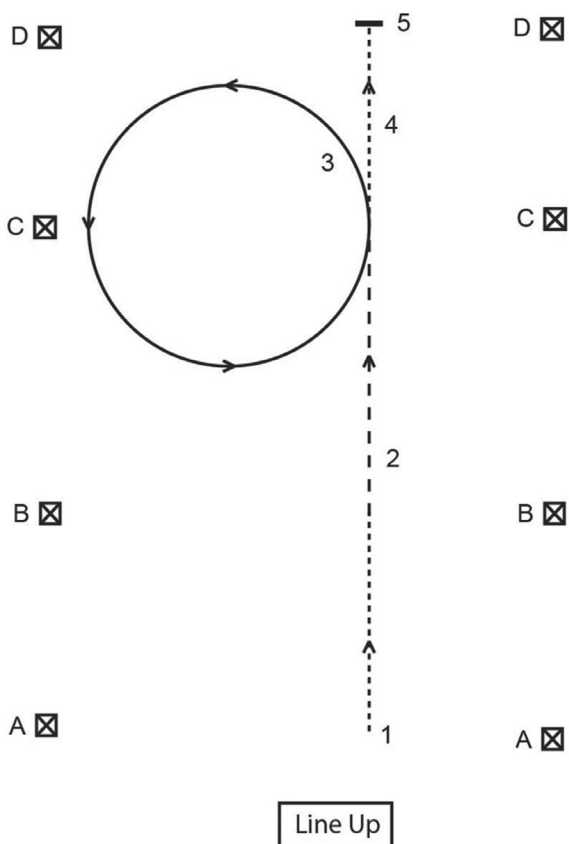

Jog: - - - - - Lope: _____
 Walk: Stop: —

1. Walk from A to B.
2. Jog from B to C.
3. Lope a circle to the left.
4. Walk from C to D.
5. Halt at D.

Follow the instructions of the ring steward.

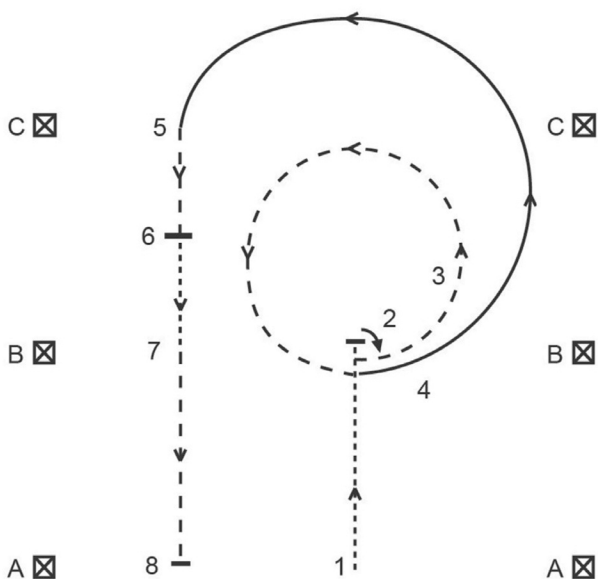

Line Up

Jog: - - - - - Lope: _____
 Walk: Stop: —

1. Walk from A to B down the center of the arena.
2. Halt at B in the center of the arena. Turn right.
3. Trot a circle to the left.
4. Left lead lope part of a circle around to C as shown.
5. Trot at C.
6. Come to a balanced, gradual stop between B and C.
7. Walk to B.
8. Jog from B to A.
9. Halt at A.

Follow the instructions of the ring steward.

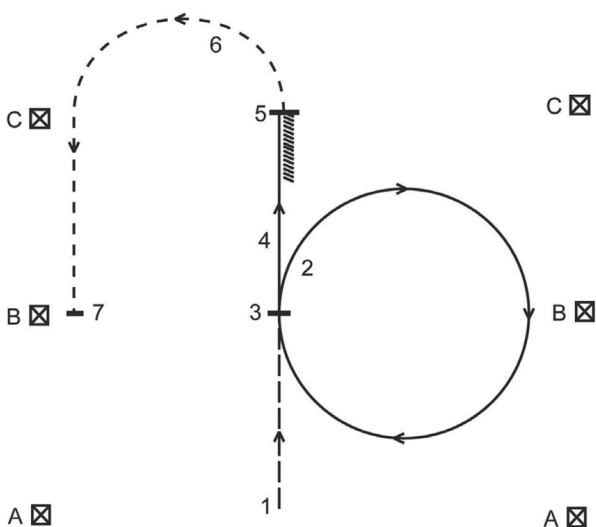

Line Up

Jog: - - - - - Lope: _____
 Extended Jog: _ _ _ _ _ Back: // // // // //

1. Extended jog from A to B.
2. Lope a circle to the right.
3. Halt at B.
4. Left lead lope a straight line from B to C.
5. Halt at C and back.
6. Build a loop. Jog around C until even with B, as shown, while swinging loop.
7. Halt even with B.

Follow the instructions of the ring steward.

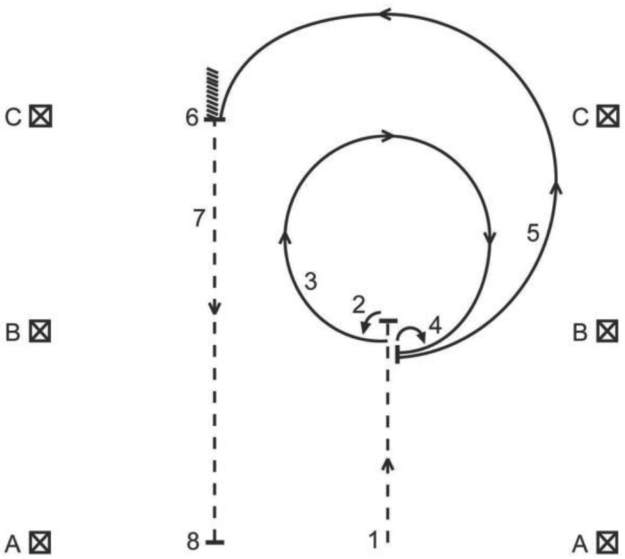

Line Up

Walk: Lope: _____
 Back: ////////////// Jog: - - - - -

1. Jog from A to B down center of arena.
2. Halt at B. 90° hindquarter turn to the left.
3. Lope a circle to the right.
4. Halt at B in the center of the arena. 180° hindquarter turn to the right.
5. Left lead lope part of a circle around to C as shown.
6. Halt at C and back.
7. Build a loop. Jog a straight line while swinging loop.
8. Halt even with A.

Follow the instructions of the ring steward.

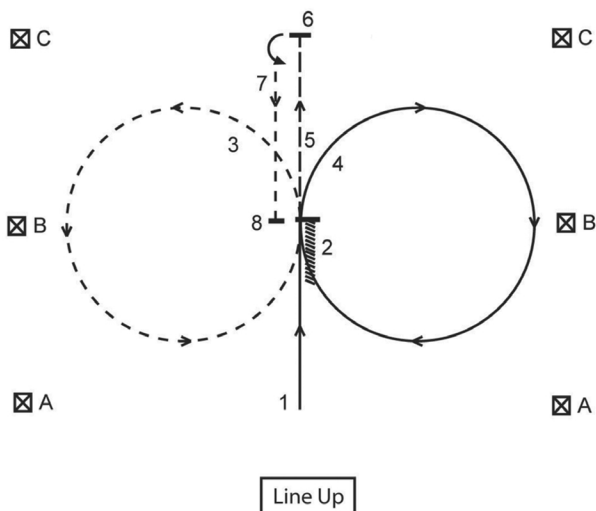

Jog: - - - - - Lope: _____
 Extended Jog: - - - - - Back: // // // // //

1. Lope on left lead from A to B.
2. Halt at B and back.
3. Jog a circle to the left.
4. Lope a circle to the right.
5. Extended jog from B to C.
6. Halt at C. 180° hindquarter turn to the left.
7. Build a loop. Jog back to B while swinging loop.
8. Halt at B.

Follow the instructions of the ring steward.

319. Pattern 1 – Level III Ranch Horsemanship

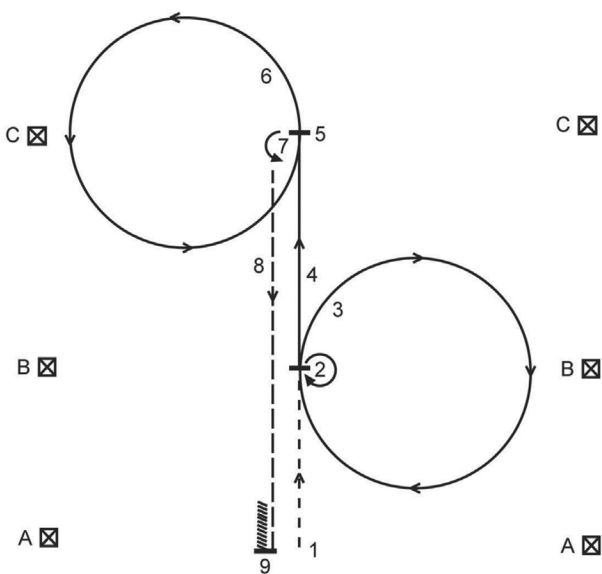

Line Up

Jog: - - - - - Lope: _____
 Extended Jog: - - - - - Back: // // // // //

1. Jog from A to B.
2. Halt at B. 360° hindquarter turn to the right.
3. Lope a circle to the right.
4. Continue loping in a straight line to C.
5. Halt at C.
6. Build a loop. Lope a circle to the left centered on C while swinging loop.
7. Halt at C and recoil rope. 180° hindquarter turn to the left.
8. Extended jog to A.
9. Halt at A and back one horse length.

Follow the instructions of the ring steward.

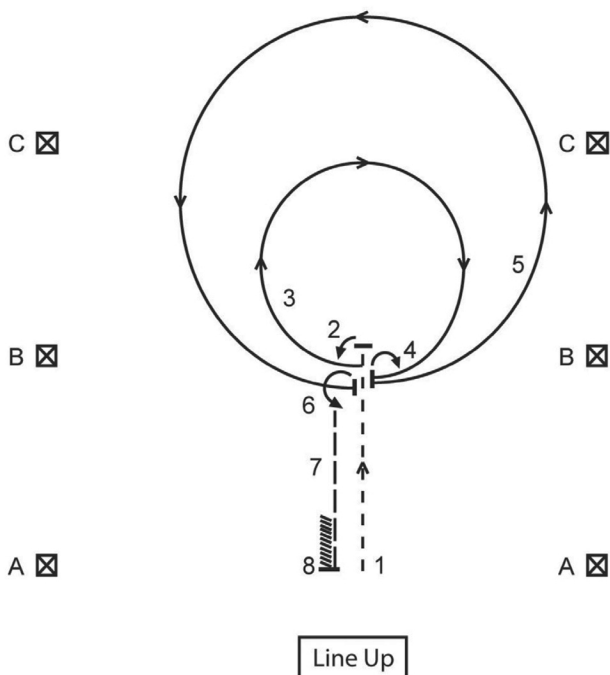

Jog: _ _ _ _ _ Lope: _____
 Extended Jog: _ _ _ _ _ Back: // // // // //

1. Jog from A to B down the center of the arena.
2. Halt at B. 90° hindquarter turn to the left.
3. Build a loop. Lope a right circle while swinging loop.
4. Halt at center and recoil rope. 180° hindquarter turn to the right.
5. Lope a large fast circle to the left.
6. Halt at center. 270° hindquarter turn to the left.
7. Extend the jog to A.
8. Halt at A and back one horse length.

Follow the instructions of the ring steward.

321. Pattern 3 – Level III Ranch Horsemanship

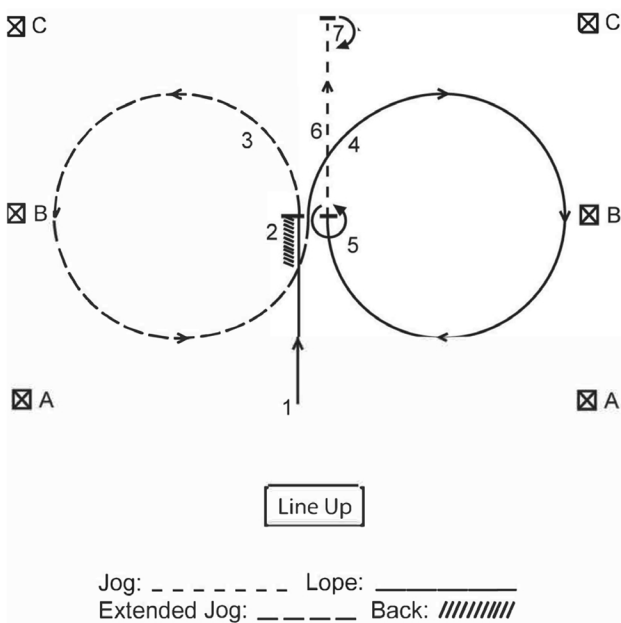

1. Build a loop at A. Left leadlope from A to B while swinging loop.
2. Halt at B and recoil rope. Back one horse length.
3. Extended jog in a circle to the left.
4. Lope a circle to the right.
5. Halt at B. 360° hindquarter turn to the left.
6. Jog to C.
7. Halt at C. 180° hindquarter turn to the right.

Follow the instructions of the ring steward.

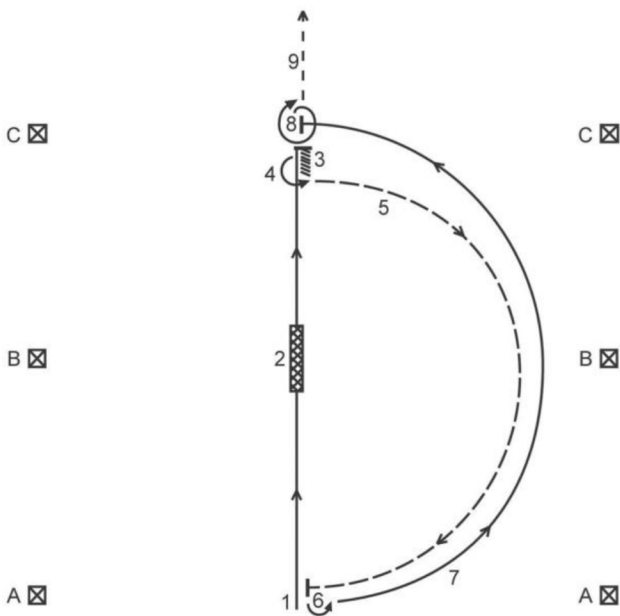

Line Up

Jog: - - - - - Lope: _____
 Extended Jog: _ _ _ _ _ Back: // // // // //
 Lead Changing Area:

1. Starting on the right lead, lope from A to B down the center of the arena.
2. Flying lead change at B. Continue loping straight.
3. Halt at C. Back one horse length.
4. 270° hindquarter turn to the left.
5. Extended jog half a circle to A.
6. Halt at A. 180° hindquarter turn to the left.
7. Build a loop. Lope a half circle to the left while swinging the loop.
8. Halt at C and recoil rope. 450° hindquarter turn to the right.
9. Jog into new line up or follow the instructions of the ring steward.

RANCH CATTLE SORTING

323. Ranch cattle sorting is a demonstration of the common chores involved in sorting cattle for doctoring, weaning, branding, sifting and sorting for market. The contestant should demonstrate their knowledge of cattle and how to influence cattle movements with the help of a quiet and responsive horse.
324. Tack and Attire (see #300)
325. Cattle sorting is an individually judged event with a three minute time limit. This event is a judged event, excessive speed is discouraged. Contestants will sort up to three head of cattle in a run.
- No credit will be given for finishing early and each cow will be scored separately on degree of difficulty and the contestant's ability to handle the cow.**
326. Turnback Riders – The contestant will choose two herd holders and a turnback rider (optional). The herd holders and turnback rider may be contestants or adults and must be mounted on horseback.
- A. Turnback riders assist in keeping the herd in the designated area. They may push unwanted and previously sorted cattle back into the herd. Turn back riders should avoid getting in the way of the contestant or doing any of the sorting.

Set Up

327. The distance of the sort line from the herd holding area should be a minimum of 30' up to a maximum of 100'. However contest management may adjust the distance to accommodate individual arena situations. The sorting line may be indicated by a white line on the arena surface, a flag on the fence lines, cones or other clearly visible marker.
328. A minimum of ten (10) head of cattle will be assembled in a pen. The cattle will be clearly marked with the numbers 0-9 (0-the highest number of cattle present).
- A. If one cow has a number that is faulty or missing, that cow can be used provided the announcer identifies the faulty cow. If more than one cow has a number that is faulty or missing, the faulty numbers must be replaced.
- B. All cattle will be sorted once before calling cattle numbers a second time, this is to prevent overworking one or two head.
- C. Cattle will be rotated to prevent them from being exhausted; every 3 runs is recommended.

- D. Cattle will be an appropriate age, size and demeanor for the event. Caution should be used when selecting cattle to ensure safety and appropriateness for the class at the discretion of show management.
- E. Abuse of cattle by either the rider or the horse will be grounds for disqualification.

Class Routine

- 329. The contestant and herd holders will start outside the sorting line, when the announcer calls the first number to be sorted the contestant and herd holders will enter the sorting area. A flagger or the announcer will signal the start of the competitor's time when the contestant crosses the sorting line.
- 330. The contestant sorts the cattle in ascending numeric order, starting with their designated number. The designated number is determined by blind draw. When the highest number is sorted, the next number to be sorted is the lowest number. For example, if a rider sorts animal #8 and then animal #9, the rider would then sort animal #0. The cattle must be intentionally and individually sorted. If more than one animal crosses the sort line, even if it is the next animal to be sorted, it must be brought back to the herd and sorted out, individually, in order to be counted as successfully sorted. Example: #4 is being sorted, #5 is sticking very close to #4 and, as the contestant pushes #4 across the line, #5 follows. In that instance, #5 must be brought back to the herd and intentionally sorted.
- 331. Cattle are considered successfully sorted when all four legs cross the sort line. Where the animal goes, after crossing the sort line, is not relevant to the contest. Cattle will usually rejoin the herd and should be allowed to do so. Cattle need to be intentionally sorted in order to be considered a qualifying sort. At no time shall more than three head be permitted to cross the sort line at the same time. Allowing more than three head to cross the sort line at the same time shall be cause for disqualification. Cattle previously sorted can return across the line.
- 332. The contestant will continue to sort until 3 head of cattle are sorted or until time is called:
 - A. Contestant will receive a 30 second warning, 2:30 into their run.
 - B. Riders will stop sorting if the judge blows a whistle.
- 333. Unusable Cows
 - A. An unusable cow shall be defined as an animal that falls down behind the line, leaves (or partially) leaves the arena, or whose legs or body become entangled in the arena structure.

- B. In case of an unusable cow the options include (but are not limited to):
1. If the cow is deemed usable by the judge, the team will be allowed to continue with the time remaining on the clock.
 2. The unusable cow may be removed and replaced with another cow, the herd will be resettled and the contestant will continue with the time remaining on the clock.
 3. The unusable cow may be removed, the herd settled and the contestant may start over with a full 3 minutes on the clock.
 4. Disqualify the team for unnecessary roughness, based on the conditions of the animal going down.

Scoring

334. Scoring will be on a basis of 0 to 100, with a 70 denoting an average score. A contestant that sorts two head of cattle may place over a contestant that sorts three head of cattle, if their skill and performance warrant, as this is a judged event, not a timed event.
335. The use of the 4-H Ranch Cattle Sorting score card is required. Management should encourage the posting of the judge's score card as a learning tool for the exhibitors.
- A. The score card will be used by the judge to evaluate the following:
1. Level of ability of herd work
 2. Control of the cow
 3. Eye appeal
 4. Degree of difficulty
 5. Cow sense
 6. Horsemanship
 7. Use of herd help
- B. Penalties will be taken for the following:
1. **One Point**
 - a. loss of working advantage
 - b. working out of position
 - c. noise directed at cattle
 - d. toe, foot, or stirrup on shoulder
 2. **Three Point**
 - a. cattle scattered or picked up
 - b. back fence
 3. **Five Point**
 - a. quitting the cow
 - b. losing the cow
 - c. changing cattle after a specific commitment
 - d. failure to separate a single animal after leaving the herd
 - e. blatant disobedience: kicking, biting, striking, rearing, etc.
 - f. rider spurring or hitting in front of the cinch at any time
 - g. each cow not sorted out of three

4. **Zero Score – not eligible for placing or awards**
 - a. illegal use of equipment
 - b. illegal use of hands (See Rule 300D, page 94)
 - c. horse turns tail
 - d. leaves working area before sort is completed with time remaining
 - e. fall of horse or rider
 - f. visible blood inside the mouth, on shoulder or sides
 - g. excessive disturbance of the herd or running into the herd

5. Disqualification will result from the following:
 - a. abuse of horse
 - b. abuse of cattle, including but not limited to running cow into fence
 - c. verbal or physical unsportsmanlike conduct towards judge or show management
 - d. herd holders that aid the contestant inappropriately. This would include entering the herd and cutting out selected animals or driving selected animals over the sorting line.
 - e. more than 3 head crossing the line at the same time (see rule 331)

C. Credit will be given for the following:

1. Good horsemanship
2. Lightness of aids
3. Willingness of the horse
4. Partnership between horse and rider
5. Good stockmanship
6. Cattle are sorted in a time-efficient manner with minimum stress to the cattle
7. Rider allows horse to rate cattle and demonstrate “cow sense”
8. Accurate and smooth sorting
9. Calm and quiet herd entry and movement
10. Using herd holders appropriately

D. When working a cow, the rider shall **NOT** be penalized for holding onto the cantle or horn of the saddle.

RANCH TRAIL

336. This class consists of a course of at least 6 obstacles and a max of 10 designed to show the horse's ability and willingness to perform normal ranch tasks. The 4-H Ranch Trail score card is required of judges and show management. Refer to rules 216-218 for scoring. Management should encourage the posting of judge's ranch trail score card as a learning tool for the exhibitors.
337. General
- A. Course will require all three gaits (walk, jog and lope) at least once, a distance of at least 30', for each of these gaits is recommended to allow the quality and suitability of gaits to be judged.
 - B. As each obstacle is negotiated, the judge will evaluate the rider's ability to handle the ranch horse through the obstacles as well as the horse's performance. Emphasis should be placed on willingness to perform, manners, response to rider and attitude.
 - C. Judge will limit riders to 3 refusals per obstacle.
 - D. The contestant shall be penalized for unnecessary delay in approaching obstacles or for excessive slowness in gaits or progress through the course.
 - E. Credit will be given to a contestant whose horse shows the ability to work on their own when obstacles warrant and willingly respond to guidance on more difficult obstacles.
 - F. The course must be posted at least one hour prior to scheduled time of class.
 - G. The course must be reset after each contestant's go.
338. Tack and Attire (see #300)
339. Obstacles – Safety should be considered when choosing and designing the obstacles. Show management may select from the list of obstacles suggested here or create their own, however safety and suitability to the contestant's age and level should be taken into consideration.
- A. The Judge has the right and duty to alter the course in any manner or remove any obstacle deemed unsafe.
 - B. **Acceptable Obstacles**
 - 1. **Working a gate unmounted.** Rider dismounts, leads their horse through the gate and without letting go of the gate, they turn their horse close the gate and remount.

2. **Working a gate mounted.** Side pass up to the gate, transfer reins to one hand if necessary, unlatch gate, push or pull gate as appropriate, pass through gate without letting go of the gate, close and latch gate. Gate should only be opened enough to let horse pass through while not allowing cattle to get out.
3. **Traverse an incline.** Horse should willingly and safely travel either up or down a slope while maintaining the desired gait. Rider's position should facilitate the horse's efforts to negotiate the incline.
4. **Swing rope.** Demonstrate building a loop and swinging a loop, may be asked for at the halt, walk, trot or lope as level requirements dictate. For Level I riders, swinging the rope is to be performed on the ground only.
5. **Throw rope.** Demonstrate swinging and throwing a loop at a roping dummy or steer head. Breakaway honda or normal honda may be used. The exhibitor will get only one attempt to catch the dummy. What is being judged is the swing and throwing a loop. For Level I riders, throwing rope is to be performed on the ground only.
6. **Drag a log.** Course may be straight, serpentine around cones or a complete circle. Rope must be dallied around the horn as level requirements dictate. A log drag is not to be included for Level I riders.
7. **Water hazard.** The horse should be willing to cross a small ditch, creek or pond (simulated water obstacle may be used). No slick bottom obstacles may be used.
8. **Hobble and/or ground tie.** Horse must remain in place while rider performs a normal ranch task such as moving a rail, fixing a fence, or checking hooves. If the horse moves 2 or less steps it will be a 1 point penalty, more than 2 steps will result in a 3 point penalty.
9. **Slicker.** Rider approaches slicker while mounted, dons slicker, may be asked to perform another obstacle, doff slicker and return it to designated place.
10. Remove, carry and place an item such as a letter, rope, slicker, canteen.
11. **Bridge.** Horse shows willingness to walk over a simulated or actual bridge (walk only).
12. Ride over logs or brush at walk, trot or lope.
13. Ride over elevated or unevenly placed logs at a walk.
14. Ride through cattle, safely and quietly.
15. Dismount unbridle and bridle their horse, mount.
16. See also 221 for additional obstacles.

C. Unacceptable obstacles

1. Tires
2. Live animals, other than cattle
3. Hides
4. PVC pipe
5. Poles elevated higher than 12 inches.
6. Rocking or moving bridges
7. Water box with floating or moving parts
8. Flames, dry ice, fire extinguisher, etc.
9. Logs or poles that can easily roll out of place
10. Plastic sheets or tarps that are stepped on

INDIVIDUAL COW WORK

340. This class combines the reining ability, stockmanship and roping ability of the rider with the responsiveness of a well-trained cowhorse. Each exhibitor will perform individually and will be judged on horsemanship, stockmanship and roping skills. This class may be combined with Ranch Horsemanship OR Ranch Riding in order of Horsemanship/Riding pattern followed by release of cow for Cow Work boxing and rest of Individual Cow Work. Use of the 4-H Individual Cow Work score card is required. Management should encourage the posting of the judge's individual cow work score card as a learning tool for the exhibitors.
- A. Riders must use caution in working a cow to minimize the chance of the cow being hurt.
 - B. The rider begins their go by calling for a cow to be turned into the arena. The time begins when the gate is closed behind the cow.
 - C. **Box and Drive**- Level II riders will box for 50 seconds. When notified by the announcer, the rider will take the cow down one side of the arena past the halfway mark and perform a responsive square stop. Rider must not attempt to stop or turn cow once it has gone down the fence. Riders are allowed a minute and a half to complete the class/run.
 - D. Level III/IV riders will box, fence, and circle or rope. Riders are allowed 3 minutes to complete the class.
 - E. Blowing one whistle will terminate the work and two whistles will award a new cow.
341. Fence Work
- A. Fence work has two parts: boxing and fencing the cow.
 - B. Boxing: When the cow is first turned into the arena, the rider must "box" or hold the cow at the prescribed end of the arena, not allowing her to leave. When the rider feels that his/her horse has shown the ability to hold the cow on that end, the rider then allows the cow to head down the fence.
 - C. Fencing: The rider must turn the cow once each way. The rider should make both turns on the same fence or will be penalized. There will be a center marker at the midpoint of the fence on the long side of the arena. The cow must pass this center marker before being turned back for the first time. When going down the fence, the rider should turn the cow back before reaching the far end of the arena or a penalty will be assessed. This shows that the horse has the speed to catch the cow and the ability to turn the cow back.
342. Roping/Circling
- A. After the rider has turned the cow at least once each way of the fence, the rider may take down a rope, build a loop, track and rate the cow, rope her and dally, releasing the breakaway honda; or, the rider may choose to circle the cow, once in each direction.

- B. If roping, the rider is allowed two throws. The judge will score the rider on how well the rope is handled, the manner in which the cow is rated, throws and stops.

When roping the exhibitor will pull up after the fence work, take down the rope and proceed to rope and stop and the honda should release. Breakaway honda must be used and dally, thereby releasing the breakaway.

A catch is considered legal if it passes over the head (including a horn catch) and holds on any part of the body except the tail until the dally is taken and the breakaway honda releases.

A catch is not required. If the exhibitor does not catch a 2 point penalty is applied but the tracking and rating is still scored.

- C. An exhibitor has the option of circling the cow once in each direction instead of roping with a score for each direction of circling. To circle the cow, the exhibitor will maneuver the cow smoothly at least 360 degrees in each direction without interference from the fence. The circle's size, symmetry, speed and relative balance from right and left show control. Tightening the circles down with fast head-to-head speed will be a credit situation. The circles should be completed before the cow is exhausted. Once an exhibitor has committed to circling a cow, if the cow falls no new cow will be awarded. The exhibitor will complete the run by riding around the fallen cow to fulfil circling requirements.

Scoring

343. Scoring will be on the basis of 0-100, with 70 denoting an average performance. Each maneuver will be scored from a plus 1.5 to a minus 1.5, in 1/2 point increments.

- A. The score card will be used by the judge to evaluate the following:
1. Rating, form and quality
 2. Degree of difficulty
 3. Eye appeal
 4. Position and control
 5. Boxing
 6. Drive and turns
 7. Circle or rope (Level III/IV)

Box & Drive only will also include the following criteria

8. Courage

9. Time Worked

- B. Penalties:

1. **One Point**
 - a. Loss of working advantage
 - b. Slipping a rein
 - c. Excessive whipping, spurring, or hollering
 - d. Failure to drive cow down the fence to designated marker
 - e. For each length horse runs past cow

- f. Using corner or end of the arena to turn cow
- g. Changing sides of arena to turn cow
- h. Working out of position

2. Two Point

- a. Going around corner of arena before stopping or turning cow
- b. Driving cow down the middle of arena and stopping in the middle of the arena.
(Driving cow at least 20 ft. off the side of the arena wall would be considered middle of the arena)
- c. No catch after two loops (see rule 342.B)
(only one rope maybe carried)

3. Three Point

- a. Exhausting or overworking before driving cow down fence
- b. Knocking down cow without having working advantage
- c. Failure or refusal to turn

4. Five Point

- a. Not getting a turn each way (5 points each way)
- b. Spurring or hitting in front of the cinch at any time
- c. Blatant disobedience including kicking, biting, bucking, rearing and striking or obviously insubordinate
- d. Loss of cow

5. 10 point penalty for dropping the rope

6. Zero-Score – not eligible to place or receive a ribbon

- a. Illegal equipment or illegal use of equipment
- b. illegal use of hands (See Rule 300D, page 94)
- c. Failure to attempt part of class
- d. Excessive running or abuse of cattle, including but not limited to running cow into fence
- e. Turn tail (to turn away from cow turning tail to the cow)
- f. Out of control
- g. Fall of horse or rider
- h. Schooling horse between cows, if new cow is awarded
- i. Failure to quit working a cow after a new cow has been awarded
- j. Willful abuse including but not limited to: whipping or striking the horse with hand or equipment
- k. Visible blood inside the mouth, on shoulder or sides

- C. When working a cow, a rider shall not be penalized for holding onto the cantle or horn of the saddle.
- D. The judge, at his discretion, may award a rider a new cow based on the following:
 1. The cow will not or cannot run
 2. The cow is blind in one or both eyes
 3. The cow will not yield to the horse
 4. The cow leaves the arena
- E. The judge will whistle the rider off the cow if, at any time, the judge feels that the cow is being run too fast, is being abused in any way (including running cow into fence), or for safety. The judge will then assess a zero score for that portion of the event.

Arena Marker Setup (Markers should be hung on fence)

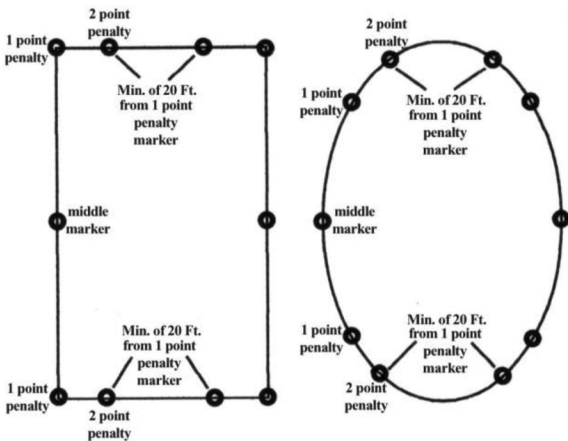

RANCH CUTTING

344. Class to be judged on the ability of the rider to work a single cow by first separating it from the herd, then driving it to the middle of the arena and holding it to demonstrate the rider's ability to work the cow and lastly, driving the cow down the arena and into a pen.
- A. Riders must use caution, in working a cow, to minimize the chance of the cow being hurt.
 - B. The minimum number of cattle in the herd shall be ten.
 - C. Cattle may be either numbered or un-numbered. If numbered, the numbers need to be easily seen by both exhibitor and judge. Note: If a cow is lost back to the herd, it is a five point penalty. If using un-numbered cattle, and the exhibitor switches cows, it will be considered "quitting the cow" and an additional five point penalty will be assessed.
 - D. The contestant will be assisted by two turnback riders who can also work as herd-holders, while the contestant separates the cow from the herd.
 - E. Cattle will be located at one end of the arena. A pen with a wing will be located on the side fence near the far end of the arena. The wing will stretch to the inside of the arena. A marker will be placed in the arena with a variable distance of 20-40 feet from the side of the arena and the corner of the pen. The marker is to be on the same side of the arena as the pen.

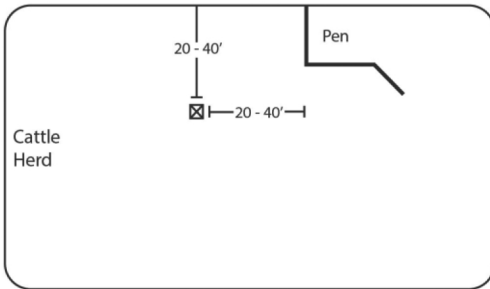

Oval arena. Each line represents a panel. Can be either 12- or 16-foot-long panels, as long as all are consistent. This is drawn where cattle would be on the left end of the arena.

- F. There is a 2 1/2 minute time limit. A verbal notification given when 1 minute remains in the run. Time begins when the rider crosses a time line, just prior to entering the herd. The cow's number is then called. The rider will quietly separate his/her numbered cow from the herd and begin their work in the order as described above.
- G. Show management may supply two turnback riders or an exhibitor may supply their own turn back riders. If an exhibitor serves as a turn back rider for someone else, he or she may use the horse that they are competing on, or they may use a different horse.

Two corner riders may also be provided or supplied by the exhibitor.

1. Guidelines for corner and turn back riders:
 - a. All four people work for the exhibitor, to assist the exhibitor, both physically and verbally, in showing his horse. Part of the score is how well exhibitor used his herd help (refer to score sheet).
 - b. Corner Riders
 - i. Keep herd centered
 - ii. Help drive herd out to aid in getting cow into center of pen
 - iii. Prevent cattle from going out into exhibitor's work
 - iv. Retrieve extra cattle after the cut is made
 - c. Turn Back Riders
 - i. Turn back unwanted cattle
 - ii. Make selected cow move if he stalls or if rider can use more pressure
 - iii. Help prevent cow from running wall to wall
 - iv. When asked, move out of way so selected cow can be driven past cone and into pen
 - v. Continue to hold herd while exhibitor pens cow
 - vi. If exhibitor loses cow while penning, turn back riders go back to holding herd to allow exhibitor to cut again and not bring out the whole herd.
 - d. Turn Back Riders and Corner Riders may not
 - i. Help cut the cow
 - ii. Help hold the cow out of herd
 - iii. Assist driving cow past cone or to pen
 - iv. Pen the cow
 - e. Verbal assistance would include, but is not limited to:
 - i. Keeping time
 - ii. Telling exhibitor when he needs to drive cow farther from the herd
 - iii. Help locate cow to be cut
 - iv. Once the cow is separated from the herd there should be limited verbal assistance. It will be at the judge's discretion to reduce the maneuver score if he or she feels there was excessive verbal assistance.

- H. When satisfied that the rider has proven the ability to keep the cow from returning to the herd, the rider will notify the turnback rider(s) to move out of exhibitors path, so as to allow the contestant to drive the cow by them. After being called off, the turnback riders can no longer assist the rider. However, the turnback riders shall continue to hold the herd, to prevent migration away from the end of the pen.
- I. The rider will drive the cow down the arena and into the pen. The cow must be driven between the fence and the marker. A rider will be assessed a 5 point penalty, if the rider does not drive the cow between the marker and the corner of the pen, prior to penning. If the cow passes on the wrong side of the marker, the rider can bring her back and then push her back toward the pen on the correct side of the marker, if time allows. It is not necessary for the rider to pass between the fence and the marker.
- J. After each rider works, the herd must be centered before the next rider begins his/her work. The judge shall indicate when the herd is sufficiently centered for the next rider to begin.

345. Scoring

Use of the ranch cutting score sheet is required of judges and show management. Management should encourage the posting of the judge's ranch cutting score sheet as a learning tool for the exhibitors.

Scoring will be on the basis of 0-100, with 70 denoting an average performance. Each maneuver will be scored from a plus 1.5 to a minus 1.5, in 1/2 point increments.

- A. The score sheet will be used by the judge to evaluate the following:
 - 1. Level of ability in herd work
 - 2. Driving and setting up the cow to cut
 - 3. Degree of difficulty of the cow drawn
 - 4. Cow sense
 - 5. Horsemanship
 - 6. Use of herd help
 - 7. Ability to drive and pen the cow within the two and one-half minutes allowed
- B. Penalties:
 - 1. **One Point**
 - a. Loss of working advantage
 - b. Working out of position
 - 2. **Three Points**
 - a. Cattle picked up or scattered
 - b. Spurring in front of the cinch
 - c. Horse pawing or biting cattle
 - d. Back fence

3. **Five Points**

- a. Quitting the cow
- b. Losing the cow
- c. Not driving the cow between the marker and corner of the pen, prior to penning
- d. Blatant disobedience

4. **Ten Points**

- a. Not penning before 2 1/2 time limit is reached
- b. Anytime more than one head enters the pen

5. **Zero Score—not eligible to place or receive a ribbon**

- a. Illegal Equipment
- b. Turn Tail
- c. Running in the herd- Excessive disturbance of the herd or running into the herd (to the point where the exhibitor is asked to leave the area)
- d. Illegal use of hands (See 300D, page 94)
- e. Herd holders aid the contestant inappropriately. This would include entering the herd and cutting out selected animals, assisting with penning of selected animal, assisting in driving animal down arena, or assisting with holding animal out of herd.
- f. Fall of horse or rider
- g. Abuse including running cow into the fence (See 343.F)
- h. Visible blood inside the mouth, on shoulder or sides (See 21 page 4)
- i. **Never successfully sorting a cow**

- C. When working a cow, a rider shall not be penalized for holding onto the cantle or horn of the saddle.

346. New Cow—Only when cows are numbered, the judge, at his discretion, may award a rider a new cow based on the following:

- A. The cow will not or cannot run
- B. The cow will not leave the herd or the end of the arena
- C. The cow is blind or will not yield to the horse
- D. The cow leaves the arena

347.-349.—NOT ASSIGNED

RANCH RIDING

350. The purpose of the ranch riding class is to measure the ability of the horse to be a pleasure to ride while being used as a means of conveyance from performing one ranch task to another. The horse should reflect the versatility, attitude and movement of a working ranch horse riding outside the confines of an arena. The horse should be well-trained, relaxed, quiet, soft and cadenced at all gaits. The ideal ranch horse will travel with forward movement and demonstrate an obvious lengthening of stride at extended gaits. The horse can be ridden with light contact or on a relatively loose rein without requiring undue restraint, but not shown on a full drape of reins. The overall manners and responsiveness of the ranch riding horse to make timely transitions in a smooth and correct manner, as well as the quality of the movement are of primary considerations. The ideal ranch riding horse should have a natural head carriage at each gait.
351. Each horse will work individually, performing the required gait maneuvers and minimum of three optional maneuvers. Horses will be scored on the basis of 0 to 100, with 70 denoting an average performance. Each maneuver will receive a score that should be added or subtracted from 70 and is subject to a penalty that should be subtracted. Each maneuver will be scored on the following basis, ranging from plus 1.5 to minus 1.5: -1.5 Extremely Poor, -1 Very Poor, -.5 Poor, 0 Correct, +.5 Good, +1 Very Good, +1.5 Excellent. Maneuver scores are to be determined and assessed independently of penalty points.
352. Gaits/maneuvers – (Judges should ensure that the patterns used are appropriate for the rider's level and adjust them accordingly.)
- A. Required: will include the walk, trot, and lope both directions: and the extended trot and extended lope at least one direction; as well as stops, and back. Exception: Extended gaits in patterns for level I and II riders.
 - B. Optional maneuvers may include a side pass, turns of 360 degrees or more, change of lead (simple or flying), walk, trot, or lope over a log(s); or some reasonable combination of maneuvers that would be reasonable for a horse to perform or encounter during ranch work.
353. One of the suggested patterns may be used (markers or signs maybe placed along the arena at the show managements discretion). A judge or show management may utilize a different pattern as long as all the required maneuvers and three (or more) optional maneuvers are included. Should a judge or show management use one of their own patterns, it is recommended to not have the stop following an extended lope.
354. Posting at the extended trot is acceptable.
355. Touching or holding the saddle horn is acceptable.

356. Ranch Riding Penalties. A contestant shall be penalized each time the following occur:

A. One (1) Point Penalties

1. Too slow/per gait
2. Over-bridled
3. Out of frame
4. Break of gait at walk or trot for 2 strides or less

B. Three (3) Point Penalties

1. Break of gait at walk or trot for more than 2 strides
2. Break of gait at lope
3. Wrong lead or out of lead
4. Draped reins (per maneuver)
5. Out of lead or cross-cantering more than two strides when changing leads
6. Trotting more than three strides when making a simple lead change
7. Severe disturbance of any obstacle

C. Five (5) Point Penalties

1. Blatant disobedience (kick, bite, buck, rear, etc.) for each refusal

D. Twenty (20) Point Penalties

Exhibitors that do the following must be placed below horses performing all maneuvers.

1. Eliminates maneuver
2. Incomplete maneuver

This penalty is deducted for each instance one of the above listed infractions occur. The judge should note an OP (off pattern) off to the side of the final score on the score sheet to ensure the exhibitor knows and that they do not place over anyone that completed the pattern as prescribed.

E. Zero (0) score not eligible to place or receive a ribbon

1. Illegal equipment
2. Illegal use of hands (See Rule 300D, page 94)
3. Willful abuse
4. Major disobedience or schooling
5. Lameness
6. Fall of horse and rider

F. No specific penalties will be incurred for ticks/hits on logs but deduction may be made in maneuver score.

G. No specific penalties will be incurred for over/ under spins but deduction may be made in maneuver score.

357. Pattern A – Level I and II Ranch Riding

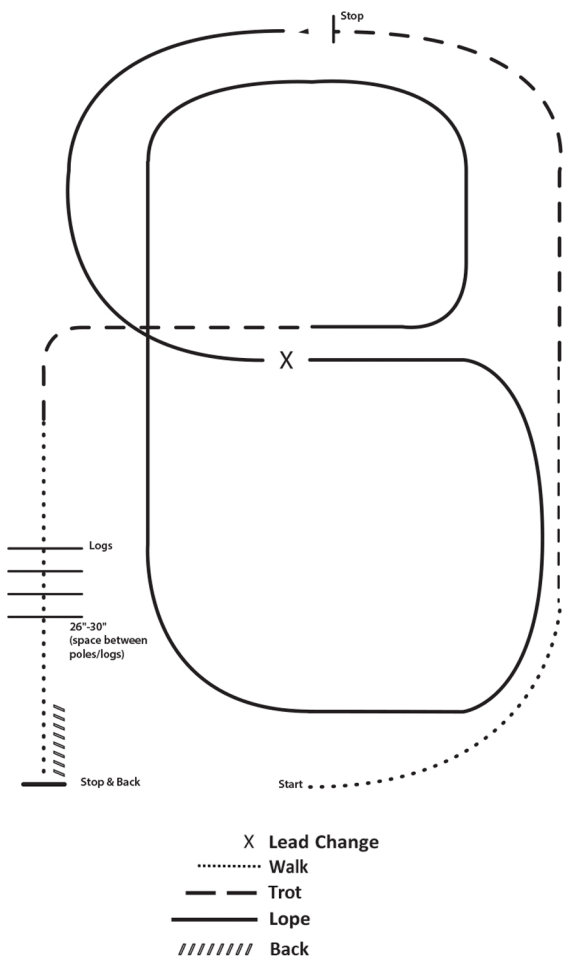

1. Walk
2. Trot to the top of the arena, stop
3. Left lead 1/2 circle, lope to the center
4. Simple lead change
5. Right lead 1/2 circle
6. Lope up the long side of the arena (right lead)
7. Lope around the top of the arena and back to center
8. Break down to a trot
9. Walk over logs
10. Stop and back

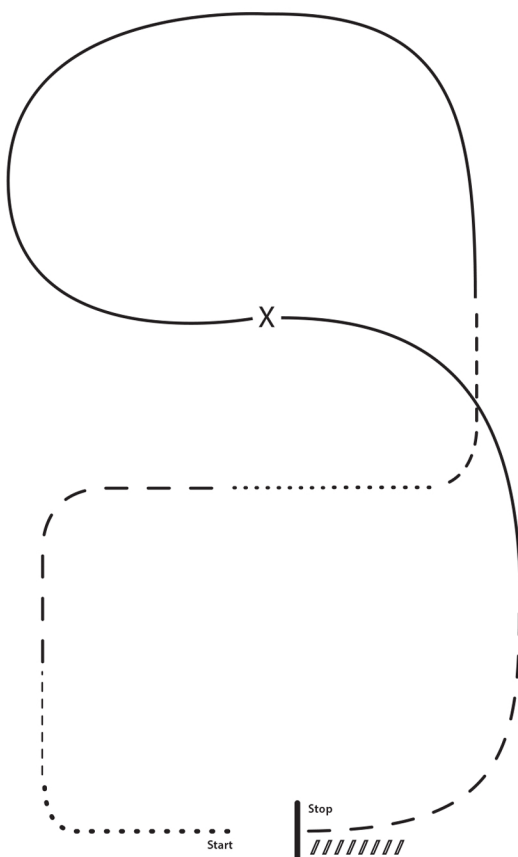

- X Lead Change
- Walk
- - - Trot
- Lope
- /////// Back

1. Walk to the left around corner of the arena
2. Trot alongside of the arena and around the corner to center
3. Walk
4. Trot
5. Lope left lead
6. Simple lead change
7. Lope on right lead
8. Trot
9. Stop and back

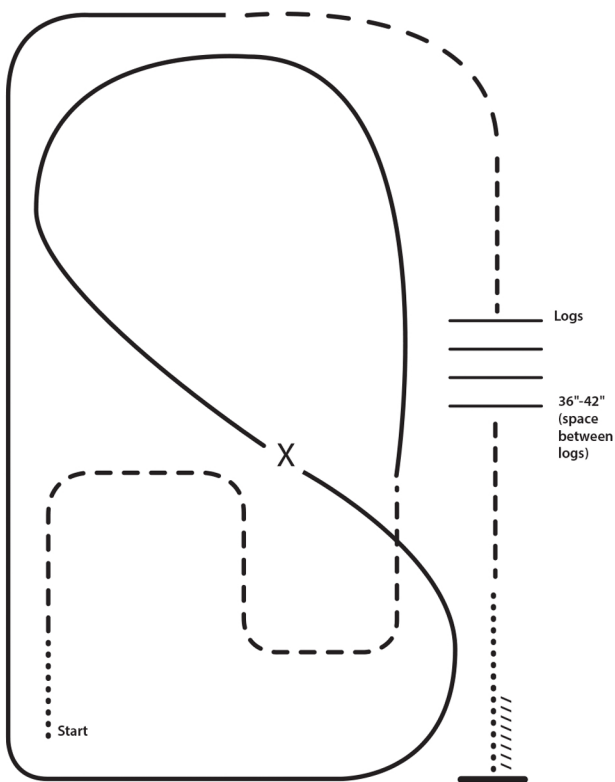

- X Lead Change
- Walk
- - - - - Trot
- Lope
- /////// Back

1. Walk
2. Trot serpentine
3. Lope left lead around the end of the arena then diagonally across the arena
4. Simple lead change
5. Lope on the right lead around end of the arena
6. Lope on the straight away and around corner to the center of the arena
7. Trot around corner of the arena
8. Trot over logs
9. Walk, stop and back

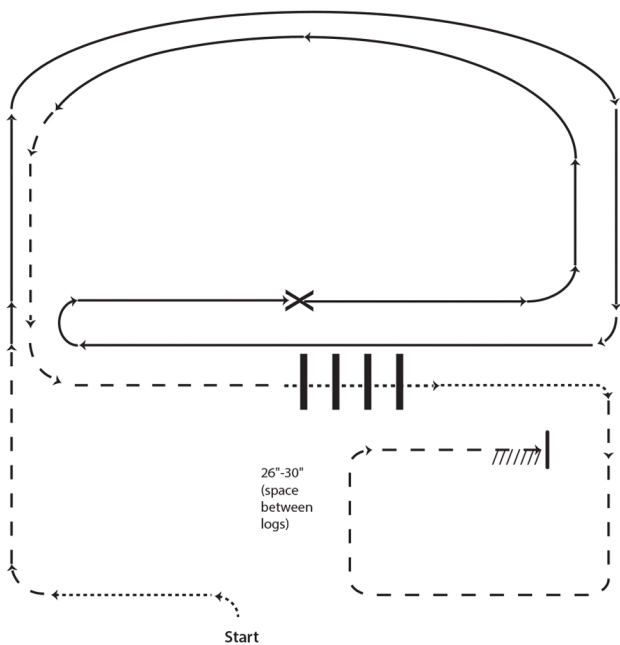

- X Lead Change
- Walk
- - - Trot
- Lope
- /////// Back

1. Walk
2. Trot
3. Lope right lead
4. Simple lead change
5. Lope left lead
6. Trot
7. Walk over logs
8. Trot square
9. Stop, back

362. Pattern 1 – Ranch Riding

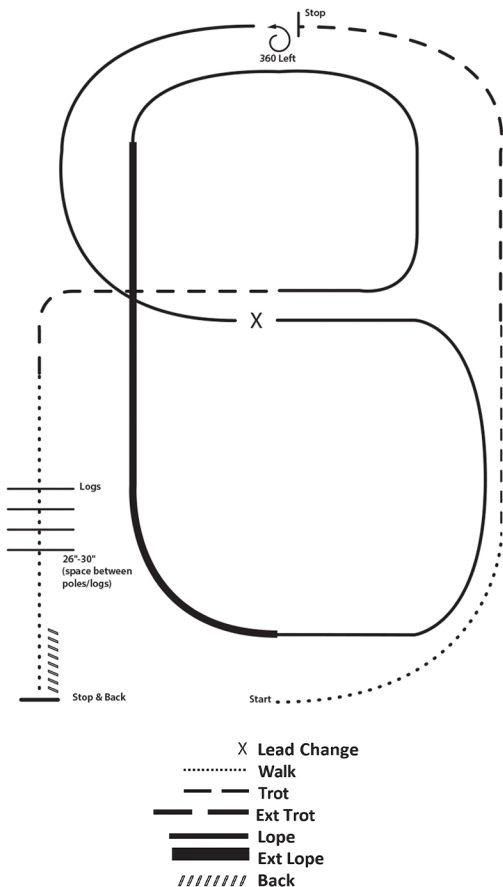

1. Walk
2. Trot
3. Extend the trot, at the top of the arena, stop
4. 360 degree turn to the left
5. Left lead 1/2 circle, lope to the center
6. Change leads (simple or flying)
7. Right lead 1/2 circle
8. Extended lope up the long side of the arena (right lead)
9. Collect back to a lope around the top of the arena and back to center
10. Break down to an extended trot
11. Walk over logs
12. Stop and back

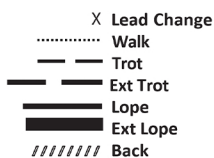
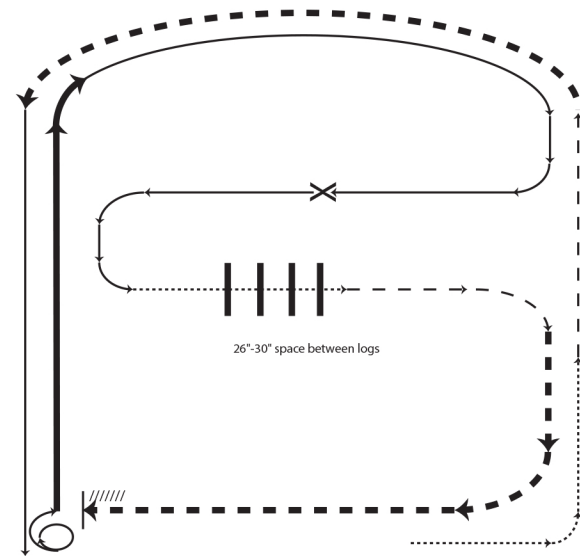

1. Walk
2. Trot
3. Extended trot
4. Left lead lope
5. Stop, 1 ½ turn right
6. Extended lope
7. Collect to working lope right lead
8. Change leads (simple or flying)
9. Walk
10. Walk over logs
11. Trot
12. Extended trot
13. Stop and back

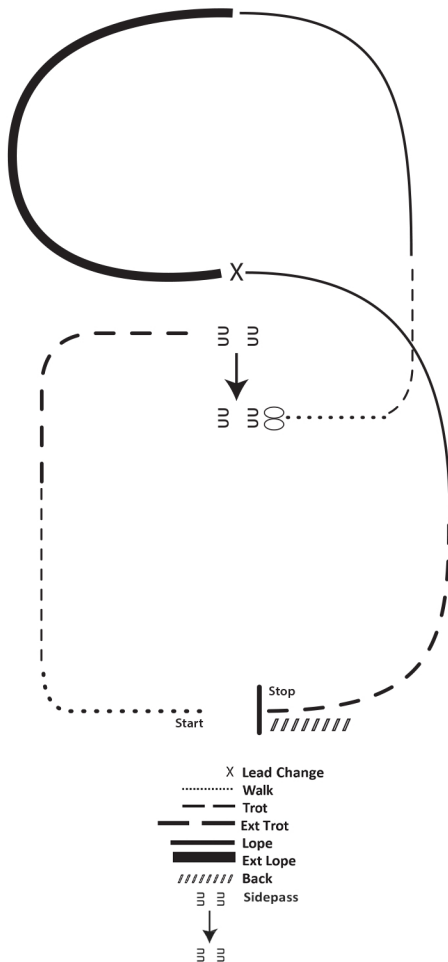

1. Walk to the left around corner of the arena
2. Trot
3. Extend trot alongside of the arena and around the corner to center
4. Stop, side pass right
5. 360 degree turn each directions (either way first)
6. Walk
7. Trot
8. Lope left lead
9. Extend the lope
10. Change leads (simple or flying)
11. Collect to the lope
12. Extend trot
13. Stop and back

365. Pattern 4 – Ranch Riding

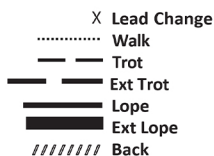
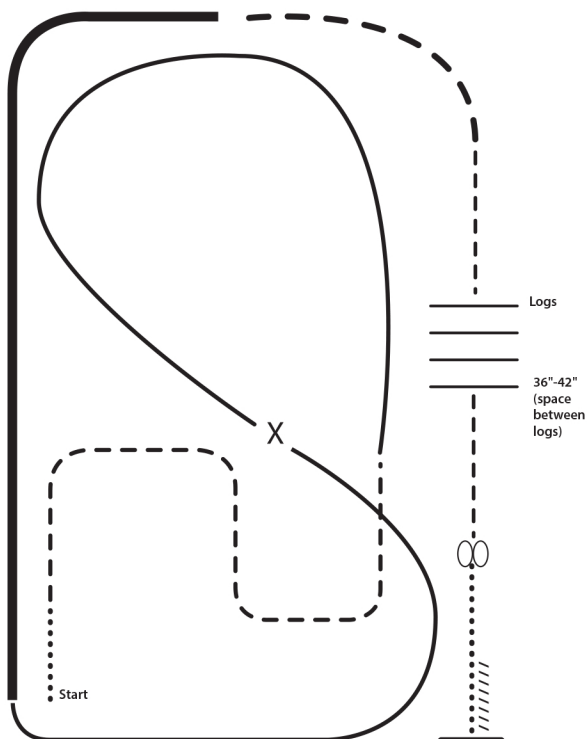

1. Walk
2. Trot serpentine
3. Lope left lead around the end of the arena and then diagonally across the arena
4. Change leads (simple or flying) and
5. Lope on the right lead around end of the arena
6. Extend lope on the straight away and around corner to the center of the arena
7. Extend trot around corner of the arena
8. Collect to a trot
9. Trot over logs
10. Stop, do 360 degree turn each direction (either direction first) (L-R or R-L)
11. Walk, stop and back

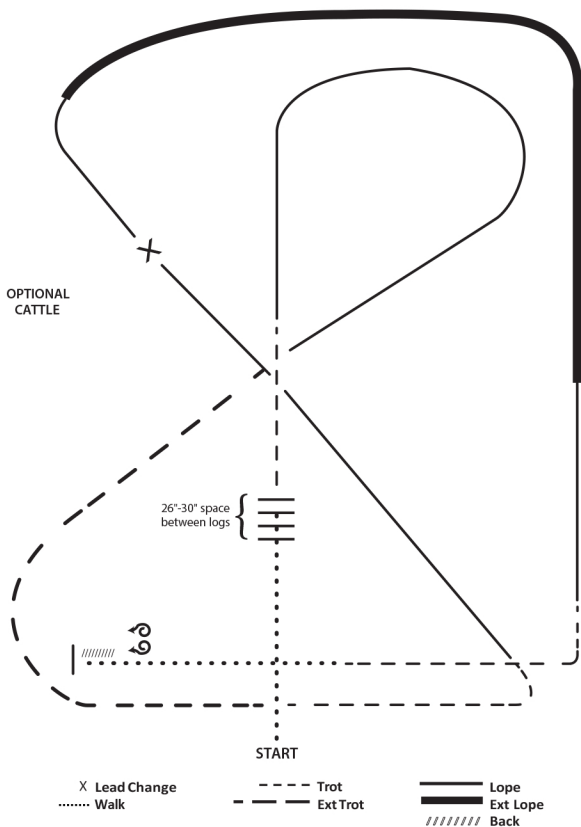

Pattern 5 - Ranch Riding

1. Walk
2. Walk over logs
3. Trot
4. Lope right lead
5. Extended trot
6. Trot
7. Lope left lead
8. Change leads (simple or flying)
9. Right lead, extended lope
10. Collect Lope
11. Trot
12. Walk
13. Stop and back
14. 360 degree turn each direction (either direction first) (L-R or R-L)

Note: The drawn description of this pattern is only intended for the general depiction of the pattern. Exhibitors should utilize the arena space to best exhibit their horses.

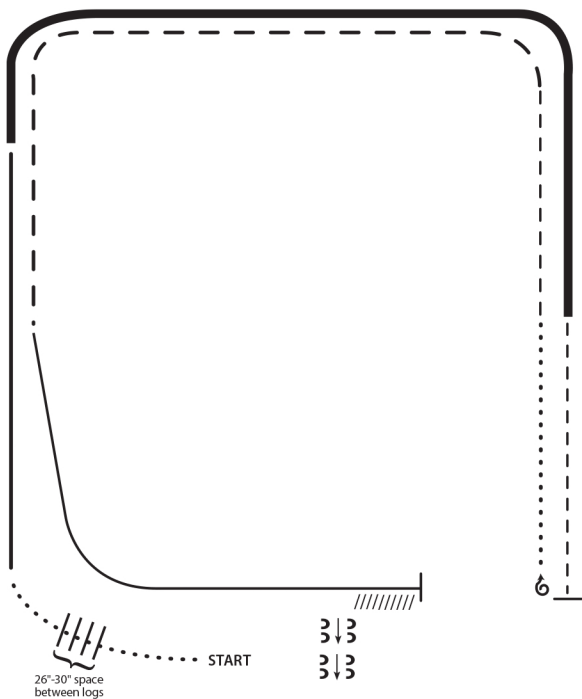

26°-30° space
between logs

START

3 ↓ 3
3 ↓ 3

X Lead Change
..... Walk

--- Trot
- - - Ext Trot

—— Lope
—— Ext Lope
///// Back

1. Walk
2. Walk over logs
3. Lope right lead
4. Extended lope (right lead)
5. Trot
6. Stop, 1 1/2 turns right
7. Walk
8. Trot
9. Extended trot
10. Lope left lead
11. Stop and Back
12. Side pass right

Note: The drawn description of this pattern is only intended for the general depiction of the pattern. Exhibitors should utilize the arena space to best exhibit their horses.

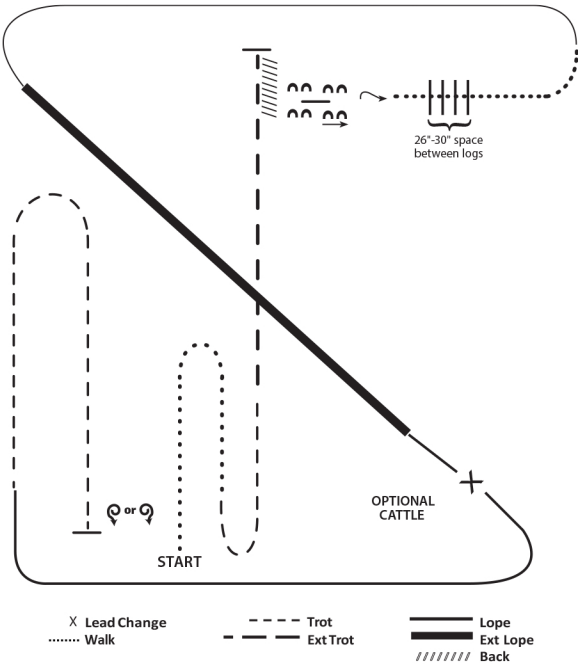

1. Walk
2. Trot
3. Extended trot
4. Stop and back
5. Side pass over log right
6. 1/4 turn right, walk over logs
7. Walk
8. Lope left lead
9. Extended lope (left lead)
10. Collect lope, change leads (simple or flying)
11. Lope right lead
12. Trot
13. Stop, one 360 degree turn either direction

Note: The drawn description of this pattern is only intended for the general depiction of the pattern. Exhibitors should utilize the arena space to best exhibit their horses.

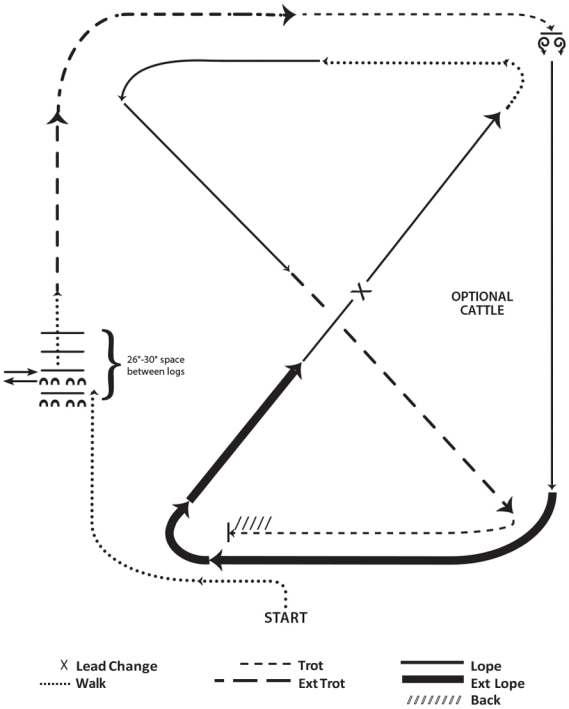

1. Walk
2. Sidepass left across first log, sidepass 1/2 way to right
3. Walk across logs
4. Extended trot
5. Trot
6. Stop, 360 degree turn each direction (either direction first) (L-R or R-L)
7. Lope right lead
8. Extended lope (right lead)
9. Collect lope, change leads (simple or flying)
10. Walk
11. Lope left lead
12. Extended trot
13. Trot
14. Stop and back

Note: The drawn description of this pattern is only intended for the general depiction of the pattern. Exhibitors should utilize the arena space to best exhibit their horses.

370. Pattern 15 – Ranch Riding

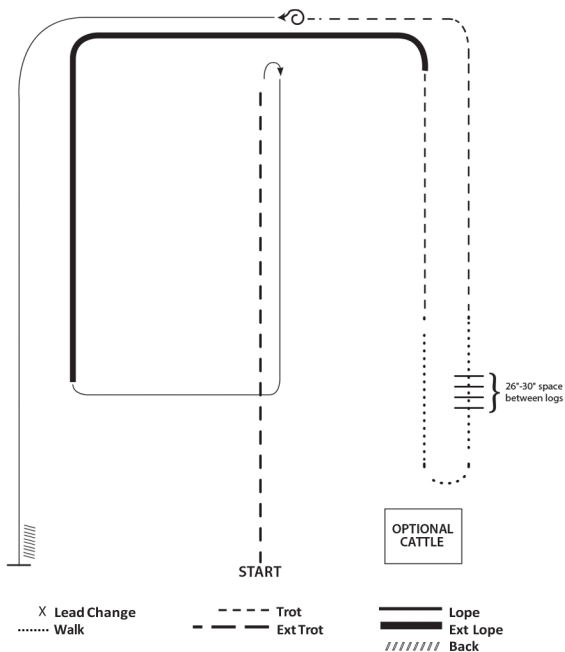

1. Extended trot
2. Stop, rollback right
3. Lope right lead
4. Extended lope (right lead)
5. Trot
6. Walk
7. Walk over logs
8. Walk
9. Trot
10. Stop, 360 left
11. Lope left lead
12. Stop and back

Note: The drawn description of this pattern is only intended for the general depiction of the pattern. Exhibitors should utilize the arena space to best exhibit their horses.

371.-399. – NOT ASSIGNED

ENGLISH DIVISION

Saddle Seat

400. In all English Division classes, it is recommended that a certified equestrian helmet with a safety harness fastened in place be worn. It is the responsibility of the parent or guardian of the 4-H member to see that the headgear worn complies with such standards and is in good condition.

401. Personal Attire

- A. Although the class is being judged on ability, the rider should be dressed in neat attire. The appointments given are based on tradition and present-day custom. Contestants who do not conform will be penalized. In extreme weather conditions, show attire requirements may be altered by show management.
- B. Informal: conservative colors are required. These include a shirt/dickey, a black, blue, gray, green, beige or brown jacket with matching jodhpurs (white jacket in season), derby or soft hat and jodhpur boots.
- C. Formal: evening wear is more conservative. A shirt/dickey with tuxedo-type jacket in dark colors including dark gray, dark brown, dark blue, or black with collars and lapels of the same color, top hat, jodhpurs to match, and gloves or dark-colored riding habit and accessories and jodhpur boots. Formal attire is not appropriate before 6 p.m.
- D. Optional: spurs of the unrowelled type.

402. Equipment

- A. Bridle: full bridles (curb and snaffle). Martingales and similar tie-downs are prohibited.
- B. Saddle: a flat, English-type is required. Forward seat or Western saddles are prohibited.
- C. Whip, up to 4' in length, including lash.

Hunt Seat

403. Personal Attire

- A. Though the class is being judged on ability rather than personal attire, riders should wear suitable hunt seat attire consisting of a shirt/dickey, a coat of any tweed or melton for hunting (conservative wash jackets in season); breeches or jodhpurs; appropriate boots; and a hunt cap is mandatory. A certified equestrian hunt cap with safety harness fastened in place is required in over fences classes. It is the responsibility of the parent or guardian of the 4-H member to see that the headgear worn complies with such standards and is in good condition.

In extreme weather conditions, show attire requirements may be altered by show management.

- B. Optional: spurs of the unrowelled type, crops and bats up to 30", no lash allowed.

404. Equipment

- A. Bridle – snaffles, pelhams, kimberwicks, or full bridles may be used. A cavesson (noseband) is required, regardless of the bridle/bit used.
- B. Saddle – English style/type saddle is required (see rule 401.B)
- C. Optional – martingales, bell boots and leg wraps are optional in Hunt Seat Equitation Over fences but are prohibited in Hunter Hack and all classes not to jump.
- D. Prohibited – western or flat saddles. Whip, figure 8 noseband, dropped nosebands, flash nosebands.

Dressage Seat

405. Personal Attire

- A. Although the individual rider is judged on ability rather than personal attire, riders should wear suitable attire consisting of a shirt/dickey, a conservative-colored hunt or dressage coat, light-colored breeches, and hunt cap or dressage derby. Certified equestrian helmets are recommended.

In extreme conditions show attire requirements may be altered by show management.

- B. Optional:
 - 1. Gloves and unrowelled spurs.
 - 2. Whip, up to 43.3" in length, including lash.

406. Equipment

- A. English-type saddle; forward, all-purpose or dressage styles. Horses will be shown in plain, smooth-mouth snaffles; cavessons are required. Drop or flash nose bands, made of leather, are permitted.
- B. Prohibited: Western or flat saddles. Martingales.

407.-409. – NOT ASSIGNED

**SADDLE SEAT EQUITATION
AND
DRESSAGE SEAT EQUITATION**

410. Judging emphasis is placed upon the rider in equitation classes. Riders will be judged on seat, hands, performance of horse, appointments of horse and rider, and suitability of horse to rider. Results as shown by the performance of the horse are NOT to be considered more important than the methods used in obtaining them.
411. No attendant shall be allowed in the ring except at the request of the judge.
412. Seat and Hands
- A. The seat should not be exaggerated. It should be efficient and most comfortable for riding the type of horse called for at any gait and for any length of time.
 - B. The hands should be held in an easy position above the withers at a height determined by where the horse carries its head. Hands should be neither perpendicular nor horizontal to the saddle. They should show sympathy, adaptability and control. The method of holding the reins is optional, except that both hands shall be used and all reins must be picked up at one time. **Bight of reins may fall on either side.**
 - C. The rider should position himself or herself correctly by sitting comfortably in the saddle without use of the irons. Find the center of gravity by sitting with a slight bend at the knees. Adjust the leathers to fit with the irons placed under the balls of the feet (not toe or "home") and with even pressure on the entire width of soles and centers of the irons. The foot position should be natural.
 - D. Maintain the positions given for the following gaits.
 - 1. Walk: slight motion in saddle.
 - 2. Trot: post with a slight elevation in the saddle; hips under body, not mechanical up-and-down, nor swinging forward and backward.
 - 3. Canter: maintain a close seat, going with the horse.
413. Class Routine
- A. The class is to enter the ring at a trot and proceed in a counter-clockwise direction. The class shall proceed around the ring at each gait and on command, reverse and repeat. The order to reverse may be executed by turning either toward or away from the rail. Entries shall line up on command and any or all riders may be required to execute any appropriate tests included in class requirements. Judges are encouraged to call for at least two tests of the top contestants. As determined by the agreement of show management and the judge, the class is to be evaluated as follows:

1. On the rail – both directions at all gaits, or
2. In combination: Rail work followed by pattern work (individual tests). When individual tests are called for, the judge's opinion should rest on a 50/50 analysis of the rail work and the individual tests. Patterns in Saddle Seat and Dressage Seat do not have cones.

414. Tests Judges May Choose From:

A. Tests for Level I

1. Pick up reins.
2. Back for three steps.
3. Performance on rail.
4. Figure 8 at trot, demonstrating a change of diagonals. Unless specified, it may be started facing the center. It must be commenced from a halt. At left diagonal, the rider should be sitting the saddle when the horse's left front leg is on the ground; at right diagonal, the rider should be sitting in the saddle when the horse's right front leg is on the ground. When circling clockwise, the rider should be on the left diagonal, when circling counterclockwise, the rider should be on the right diagonal.

B. Tests For Level II Riders

1. Any of the above
2. Ride without irons at the walk and/or trot (no longer than 1 minute).
3. Forehand turns of 90 and/or 180 degrees.
4. Hindquarter turns of 90 and/or 180 degrees.
5. Figure 8 at canter on correct lead demonstrating simple change of lead. (This is a change whereby the horse is brought back into a halt, walk, or trot, and restarted into a canter on the opposite lead.) Unless specified, it may be started either facing the center or away from the center. If started facing the center, it must start from a halt. Figures commenced in center of two circles so that one lead change is shown.
6. Simple lead changes on a straight line.

C. Tests for Level III and IV Riders – Saddle Seat

1. Any of the above tests for English I and II riders.
2. Execute a serpentine at the trot showing correct diagonal changes with or without irons.

A serpentine is a series of left and right half circles off-center of imaginary line where the correct diagonal or lead must be shown.

3. Execute a serpentine at the canter on the correct leads demonstrating a simple change of lead through the halt.

4. At canter change of leads down center of ring demonstrating simple change of lead through the halt/walk. Judge to specify exact lead changes to be executed as well as specifying the beginning lead.
5. Ride without irons for a brief period of time (no more than one minute).
6. Demonstrate a counter canter.
7. 180° Turn on the forehand.
8. 180° Turn on the haunches.
9. Demonstration ride of approximately one minute on own mount. Movements must be selected from tests above. Rider must advise the judge beforehand what ride he plans to demonstrate.

D. Tests for Level III Riders – **Dressage Seat**

1. Any of the above tests for English I and II riders.
2. Leg yield right and/or left at walk and/or sitting trot.
3. Demonstrate collected, medium, and extended gaits.
4. Shoulder in right and/or left at walk and/or sitting trot.
5. Counter Canter
6. Free walk.

E. Tests for Level IV Riders – **Dressage Seat**

1. Any of tests above for English I, II, and Dressage III riders.
2. Perform 10 meter circles at working trot sitting and/or working canter.
3. Perform traverse left and/or right at sitting trot.
4. Half pass at trot and/or canter across the diagonal.
5. Counter canter a 3 loop serpentine.
6. Flying change of lead across the diagonal.

415. See Faults in Hunt Seat Equitation (not to jump section)

416.-419. – NOT ASSIGNED

HUNT SEAT EQUITATION (NOT TO JUMP)

420. Judging emphasis is placed upon the rider in equitation classes. Riders will be judged on seat, hands, performance of horse, appointments of horse and rider, and suitability of horse to rider.
421. The results as shown by the performance of the horse are NOT to be considered more important than the methods used in obtaining them.
422. No attendant shall be allowed in the ring except at the request of the judge.
423. Seat and Hands
 - A. The rider should present a workman-like appearance of being with the horse and in light control at all times. An impression of lightness and suppleness should be conveyed.
 - B. The hands should be over and in front of the horse's withers, with knuckles about 30 degrees inside the vertical. The hands should be held slightly apart and in a position to make a straight line from the horse's mouth to the rider's elbow. Method of holding the reins is optional; all reins are to be picked up at the same time, bight of reins may fall on either side.
 - C. The rider should sit a basic position with the eyes up and shoulders back, toes at a natural angle, heels down ankle flexed in, and calf of the leg in contact with the horse slightly behind the girth. The foot must rest in the stirrup with the iron under the ball of the foot. The body should be vertical at the walk, inclined forward at the posting trot and hand gallop, and half-way between the posting trot and the walk, when at the canter.
 - D. To mount, take up the reins in the left hand and place hand on the withers. Face the horse at an oblique angle to the rear, near the shoulder. Grasp the stirrup leather with the right hand and insert the left foot in the stirrup. Swing up while placing the right hand on the pommel or cantle until upright. The right hand must then be moved to the pommel while completing the mounting process. The right leg is to be swung quietly over and close to the horse's hindquarters. The rider is then to place the right foot in the iron and settle the seat softly and quietly into the saddle.

- E. To dismount, the rider may either step down or slide down. The size of the rider must be taken into consideration. The left hand, with the reins, is to be on or in front of the horse's withers and the right hand on the pommel of the saddle while swinging the right leg over the horse's hindquarters. Disengage the right foot from the iron and swing the right leg over and close to the horse's hindquarters. When the right leg and left leg are next to each other, on the near side of the horse, the rider may continue to dismount with the right hand on the pommel of the saddle or move the right hand to the cantle of the saddle. The rider may then either step down, landing on one foot, or slide down, landing on both feet, to complete the dismount.

424. Class Routine

- A. Contestants will be asked to walk, trot, and canter both ways of the ring. Extended gaits may be requested. The order to reverse may be executed either toward or away from the rail.
- B. Light contact with the horse's mouth is required.
- C. Upon command all entries will line up and any or all riders may be required to execute any appropriate tests. Judges may call for additional tests.
- D. As determined by the agreement of show management and the judge, the class is to be evaluated as follows;
 - 1. On the rail—both directions at all gaits, or
 - 2. Individual tests, i.e., pattern work, or
 - 3. In combination: pattern work and rail work, which may be one or both ways of the arena. The judge's opinion shall rest on an analysis of the rail work and the individual tests.

425. Tests Judges May Choose From:

- A. Tests for Level I and Unrated Riders
 - 1. Pick up reins.
 - 2. Back.
 - 3. Performance on rail.
 - 4. Figure 8 at a trot, demonstrating change of diagonals. At left diagonal, rider should be sitting in the saddle when the horse's left front leg is on the ground; at right diagonal, the rider should be sitting in the saddle when the horse's right front leg is on the ground. When circling clockwise, at a trot, the rider should be on the left diagonal, when circling counter clockwise, the rider should be on the right diagonal.
- B. Tests for Level II Riders
 - 1. Any of the above.
 - 2. Ride without irons at the walk and/or trot (no longer than 1 minute).

3. Figure 8 at canter on the correct lead demonstrating a simple change of lead. (This is a change whereby the horse is brought to a walk or trot and restarted into a canter on the opposite lead). Figure 8 should be started in the center of the two circles so one change of lead is shown.
 4. Work at a collected walk, trot or canter, or extended gaits.
 5. Simple lead changes on a straight line.
 6. Sitting trot.
 7. Forehand turn 90° or 180°.
 8. Hindquarter turn 90° or 180°.
- C. Tests for Level III Riders (Hunt Seat)
1. Any of the above tests for English I and II riders.
 2. Ride without irons or drop and pick up irons.
 3. Figure 8 at canter on correct lead demonstrating a flying change of lead.
 4. Canter to hand gallop (in 2 point position), back to canter.
 5. Serpentine at posting trot showing diagonal changes.
 6. Serpentine at canter showing simple or flying change of lead.
 7. Demonstrate lengthening of frame and stride at walk, trot and/or canter.
 8. Leg yield right and left at the walk and/or sitting trot.
- D. Tests for Level IV Riders (Hunt Seat)
1. Any of tests above for English I, II, and Hunt Seat III riders.
 2. Shoulder in right and/or left at walk and/or trot.
 3. Leg yield right and/or left at canter across the diagonal.
 4. Serpentine at the trot showing diagonal changes with or without irons.
 5. Serpentine at the canter demonstrating flying lead changes.
 6. Serpentine at the canter, without a change of lead, beginning on the correct lead.
 7. Canter on the counter lead
 8. Flying change of lead on a straight line.

Scoring

426. Judges should use the 4-H Horsemanship/Equitation score card. Exhibitors are to be scored from 0 to infinity, with 70 denoting an average performance. Patterns will be divided into 6 to 10 maneuvers, as specified by the judge, and each maneuver will be scored from plus 3 to minus 3 with 1/2 point increments acceptable that will be added or subtracted from 70. Maneuver scores should be determined independent of penalties, and should reflect equal consideration of both performance of the exhibitor's pattern and the equitation form and effectiveness of the exhibitor to result in the following scores: +3 Excellent, +2 Very Good, +1 Good, 0 Average or Correct, -1 Poor, -2 Very Poor, -3 Extremely Poor. Exhibitors overall equitation form and effectiveness should also be scored from 0 to 5 with 0 to 2 Average, 3 Good, 4 Very Good, 5 Excellent. Exhibitors should also be judged on the rail, and their pattern score and/or ranking may be adjusted as appropriate.

Penalties

427. Maneuver evaluations and penalty applications are to be determined independently. The following penalties will be applied for each occurrence and will be deducted from the final score:

A. Minor One (1) Point Penalties:

1. Break of gait at the walk/trot or wrong lead up to 2 strides
2. Over or under turn 1/8 of designated turn
3. Over cueing with reins and/or legs
4. Reins too long/short or uneven
5. Failure of horse to stand still at end of pattern
6. Obviously looking for lead or diagonal
7. Incorrect diagonal for 2 or less strides
8. Tick or hit of cone

B. Major Three (3) Point Penalties:

1. Not performing the specific gait or not stopping within 10 feet (3 meters) of designated location
2. Incorrect lead or diagonal for more than 2 strides
3. Break of gait at the canter (except when correcting an incorrect lead)
4. Break of gait at walk or Trot for more than 2 strides
5. Over or under turn from 1/8 to 1/4 turn

C. Severe Five (5) Point Penalties:

1. Blatant disobedience including kicking, pawing, bucking, and rearing
2. Loss of stirrup or rein
3. Touching the horse or saddle
4. Spurring in front of the girth

D. Zero Scores (Eligible for placing but not above anyone receiving a score above zero)

1. Offpattern
2. Wrong side of cone or knocking over cone
3. Failure to perform or achieve the specified gait, lead or diagonal
4. Over/under turn more than 1/4 turn

E. Disqualifications (should not be placed):

1. Loss of control of the horse
2. Illegal Equipment or illegal use of hands on reins
3. Fall by horse or exhibitor (pg. 7, rules 40 and 41)
4. Abuse of horse or schooling

428.-429. – NOT ASSIGNED

HUNT SEAT EQUITATION OVERFENCES

Includes Level II Skills.

430. Judging emphasis is placed upon the rider in equitation classes. Riders will be judged on seat, hands, performance of horse, appointments of horse and rider, and suitability of horse to rider.
431. The results as shown by the performance of the horse are NOT to be considered more important than the methods used in obtaining them.
432. No attendant shall be allowed in the ring except at the request of the judge.
433. Course must be posted 1 hour prior to class.
434. Seat and Hands (see #423).
435. Personal attire (see #402).
Required: a hunt cap (certified equestrian approved ASTM/SEI), with safety harness fastened in place, is required when schooling or showing over fences.
436. Equipment (see #403): Martingales, boots, or leg wraps are optional.
437. Class Routine
 - A. The performance begins when the horse enters the ring or is given the signal to proceed after entering the ring. Except for refusals, jumping faults of the horse are not to be considered unless it is the result of the rider's ability.
 - B. Each contestant may circle once, if desired, before approaching the first jump. He/She shall then proceed around the course keeping an even pace throughout. Three cumulative refusals will eliminate the rider (no placing or ribbon to be awarded). If a refusal occurs in a double or triple, the rider shall rejump all elements of the combination. Any or all contestants may be called back to perform at a walk, trot and canter, or to execute any appropriate test included in class requirements.
438. Course Requirements
 - A. Classes shall consist of at least six reasonable fences. A suggested course is shown at the end of these rules, which may consist of various obstacles.
 - B. In classes with exhibitors, ages 8-10, 11-13, and/or Level III, jumps will not exceed 30" in height. Wings 30-inches wide are encouraged and groundlines are required.
 - C. In classes with exhibitors, ages 14-18, and/or Level IV, the jumps will not exceed 36" in height. Wings 30-inches wide are encouraged and groundlines are required.
 - D. In 4-H shows holding classes for all combined age and/or level riders, the jumps will not exceed 30" in height. Wings 30-inches wide are encouraged and groundlines are required.

- E. Height of fences and/or distances shall be adjusted for safety. Use the following chart for height of fences and distances:

Height of fences:	2'	2'3"	2'6"	2'9"	3'
Distances:					
3 strides (minimum)	46'6"	46'9"	47'	47'9"	48'
4 strides	58'6"	58'9"	59'	59'6"	60'
5 strides	70'	70'3"	70'6"	70'	72'
6 strides	81'6"	81'9"	82'	82'6"	84'

439. Tests may be performed either collectively or individually, but no other tests may be used. Instructions will be publicly announced.
- Back.
 - Hand gallop, halt and stand.
 - Figure 8 at a trot, demonstrating change of diagonals. At left diagonal, rider should be sitting the saddle when left front leg is on the ground; at right diagonal, rider should be sitting the saddle when right front leg is on the ground; when circling clockwise at a trot, the rider should be on left diagonal; when circling counterclockwise, rider should be on right diagonal.
 - Figure 8 at canter on the correct lead demonstrating a simple change of lead. (This is a change whereby the horse is brought back into a walk or trot, and restarted into a canter on the opposite lead.) Figure 8 to be commenced in center of the two circles so that one change of lead is shown.
 - Jump low fence at a trot, as well as canter.
 - Pull up between fences (except in a combination).
 - Jump fences on Figure 8 course.
 - Ride without irons.
 - Jump a serpentine course, demonstrating change of lead at each change of direction.
 - Figure 8 at canter on correct lead demonstrating flying change(s) of lead.
 - Change leads on a straight line demonstrating simple or flying change of lead.
 - Execute serpentine at a trot and/or canter on correct lead demonstrating simple or flying changes of lead. (A serpentine is a series of left and right half circles off center of imaginary line where correct diagonal or lead change must be shown).
 - Counter canter.
 - Half turn on forehand and/or half turn on the haunches.
 - At anytime willful abuse will not be tolerated and will result in elimination.

440. Courses or Arena Arrangement:

- A. Minimum of four obstacles. Horses are to negotiate a minimum of six jumps and a minimum of one change of direction is required.

B. Types of obstacles which may be used:

1. Fences shall simulate obstacles found in the hunting field such as post and rail, stone wall, chicken coop, Aiken hedge, ascending oxer, and so forth. A pole over brush and jumps such as triple bar and hogbacks are prohibited.
2. The top element of all fences must be securely placed so that a slight rub will not cause a knockdown.

441. Suggested Courses – Course should be in accordance with ring size and jumps available and designed by an experienced rider or trainer. It is recommended that the first fence will be an inviting jump, such as cross rail or low vertical. All rails must be free to fall. Distances between fences must be noted on the posted pattern.



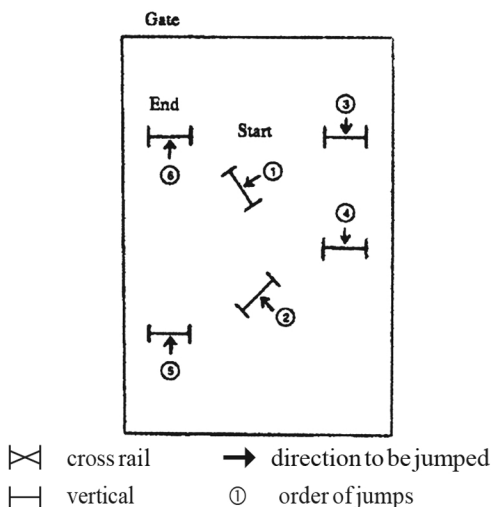

Proper execution of this pattern includes Advancement Level III skills.

A. Pattern 1

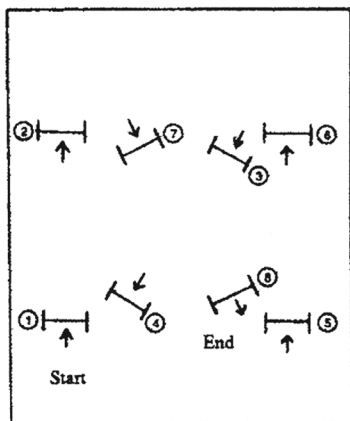

B. Pattern 2





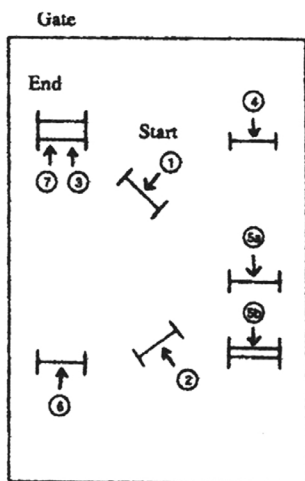

- | | | | |
|---|------------|---|------------------------|
|  | cross rail |  | direction to be jumped |
|  | vertical |  | order of jumps |

Proper execution of this pattern includes Advancement Level III skills.

C. Pattern 3



- | | | | |
|---|------------|---|------------------------|
|  | cross rail |  | direction to be jumped |
|  | vertical |  | order of jumps |
|  | oxer | | |

Proper execution of this pattern includes Advancement Level III and IV skills.

442.-449. – NOT ASSIGNED

HUNTER HACK

450. The purpose of hunter hack is to give horses an opportunity to show their expertise over low fences and on the flat. The hunter hack horse should move in the same style as a working hunter. The class will be judged on style over fences, even hunting pace, flat work, manners and way of going. The poll should be level with, or slightly above the withers, to allow proper impulsion behind. The head should not be carried behind the vertical, giving the appearance of intimidation, or be excessively nosed out, giving a resistant appearance.
451. Horses are first required to jump two fences a minimum of two feet (2') up to a maximum of two feet six inches (2'6") in height. A ground line is recommended for each jump under or slightly in front (about 12 inches) of the fence or a guideline is at the base of the standard.

Distances shall be adjusted as in the following chart. Fences to be set on a straight line down the middle of the long side of the arena or on a diagonal line across the long side of the arena.

Height of fences:	2'	2'3"	2'6"
Distances:			
3 strides (minimum)	46'6"	46'9"	47'
4 strides	58'6"	58'9"	59'
5 strides	70'	70'3"	70'6"
6 strides	81'6"	81'9"	82'

At the discretion of the judge, contestants may be asked to hand gallop, pull up or back and stand quietly following the last fence.

452. Following the individual fence portion of the class all exhibitors return to the ring and will be judged on flat work (on the rail), manners, way of going, and even hunting pace. When necessary to split large classes by running more than one go-round, finalists may be rejumped and reworked on the flat.
453. Placing for the class shall be determined by allowing a minimum of 70 percent for individual fence work and a maximum of 30 percent for work on the rail/flat.
454. Faults: Horses eliminated in the over-fence portion of the class shall be disqualified.

A. Faults Over Fences scored according to severity include:

1. Unsafe jumping and bad form over fence, whether touched or untouched, including twisting.
2. Incorrect leads around the ends of the course or cross-cantering shall be penalized,
3. Excessive use of crop.
4. Fences shall be taken in the correct number of strides
5. Rubs (front rub is to be deemed more dangerous than a hindrub)

6. Any error that endangers the horse and/or its rider, particularly refusals or knockdowns, shall be heavily penalized.

B. OverFence elimination:

1. A total of three disobediences that can include any of the following: refusal, stop, run out or extra circle.
2. Jumping an obstacle before it is reset.
3. Bolting from the arena.
4. Offcourse.
5. Deliberately addressing an obstacle.

C. Rail/flat work faults to be scored accordingly, but not cause disqualification include:

1. Being on wrong lead and/or wrong diagonal at the trot
2. Excessive speed (any gait)
3. Excessive slowness (any gait)
4. Breaking gait
5. Failure to take gait when called
6. Head carried too low or too high
7. Nosing out or flexing behind the vertical
8. Opening mouth excessively
9. Stumbling

D. Faults scored according to severity throughout the class:

1. Head carried too low and/or clearly behind the vertical excessively and consistently while the horse is in motion, or otherwise showing the appearance of intimidation.

E. At anytime willful abuse will not be tolerated and will result in elimination.

455. Personal attire (See #402)

456. Equipment (See #403)

1. Prohibited: martingales, bell boots, splint boots, leg wraps.
2. Optional: crop or bat, not to exceed 30" in length, unrowelled spurs.

457.-459. – NOT ASSIGNED

ENGLISH SHOW HACK CLASS

This advanced rail class shows collected and extended gaits. Judging emphasis is placed upon the rider and the obedience of the horse.

460. Collected and extended gaits will be called for, with collection and extension being judged by footfall within the stride. Collection (shortening) and Extension (lengthening) is being evaluated and does not equate to speed. All gaits, transitions and the ability of the rider to achieve balance and control will be considered in placing the class. Obedience shall be of prime importance. Willful abuse will not be tolerated and will result in elimination.
461. Required gaits are: normal walk, collected walk, extended walk, normal trot, collected trot, extended trot, normal canter, collected canter, and extended canter. At the discretion of the judge, the class may be split to execute the extended canter. Horses are required to perform all gaits in each direction. Reinback to be called for on the rail or in the line up.
462. Personal Attire
- A. Although the class is being judged on ability, the rider should be dressed in neat attire.
 - B. If exhibiting in the Saddle Seat style, the rider shall wear a conservative color or tuxedo style jacket with matching jodhpurs, a derby or top hat, and jodhpur boots.
 - C. If exhibiting in the Hunt Seat or Dressage Seat style, attire may include a conservative-colored hunt coat, short dressage coat or a formal shadbelly coat, light-colored breeches, tie, stock tie or choker, boots, and a top hat or hunt cap, as appropriate.
 - D. Optional in all disciplines are gloves, unrowelled spurs, bats, whips no longer than 4 feet, and safety helmets with harness fastened.
463. Equipment
- A. Any English-type saddle including flat, forward or dressage styles shall be allowed.
 - B. Bridles may be full (curb and snaffle), regular snaffles, pelhams and kimberwicks, and must include a cavesson noseband. Tack such as Figure 8, flash or dropped nosebands; martingales; boots; or bandages are prohibited. Mane and/or tail may be braided, but it is optional.
- 464.-469. – NOT ASSIGNED

ENGLISH CONTROL

470. The performance required in this class is designed to reflect a combination of controls and skills required for good English equitation and performance.

- A. Each rider will perform individually. He or she will be judged upon the skills shown in executing the required pattern.
- B. Judging emphasis will be placed upon the following points: basic position in the saddle, lightness of hands, correct and imperceptible use of aids, response of the horse as indicative of equitation ability of the rider (including correct use of diagonals), the smoothness of performance, and steadiness of the gaits. Preference will be given to proper changes of leads between the markers. Changing of leads are required. Conformation will not be considered. The rider should present a workman-like appearance of being with the horse and in light control at all times. An impression of lightness and suppleness should be conveyed.

471. Personal attire (see #401, 403, 405).

472. Equipment (see #402, 404, 406).

- A. Must conform to hunt seat, saddle seat or dressage seat requirements.
- B. Optional: spurs of the unrowelled type, crops, bats and whips.

Scoring

473. Score will be on a basis of 0-100 with 70 denoting an average score. Use of the 4-H English control score card is recommended and may be posted after the conclusion of the class. A scribe may be provided for the judge. Management should encourage the posting of the English control score card as a learning tool for the exhibitors.

Scoring guidelines to be considered: points will be added or subtracted from the maneuvers on the following basis, ranging from minus 1.5 to plus 1.5, in 1/2 point increments. In addition, any penalty scores accrued in a maneuver are to be subtracted from each maneuver score: -1.5 Extremely Poor, -1 Very Poor, -.5 Poor, 0 Average, +.5 Good, +1 Very Good, +1.5 Excellent.

Penalties

474. An exhibitor should be penalized in the pattern independent of maneuver scores and deducted from the final score as follows:

A. One (1) Point

1. Break of gait at the walk or trot up to 2 strides
2. Missing a diagonal up to 2 strides
3. Over or under turn from 1/8 to 1/4 turn
4. Tick or hit of cone
5. Obviously looking down to check leads or diagonals

B. Three (3) Points

1. Not performing the specific gait or not stopping within 10 feet of designated location
2. Missing a diagonal for more than 2 strides
3. Incorrect lead or break of gait at the canter (except when correcting an incorrect lead)
4. Complete loss of contact between rider's hand and the horse's mouth
5. Break of gait at walk or trot for more than 2 strides
6. Loss of iron
7. Head carried too low and/or clearly behind the vertical while the horse is in motion, showing the appearance of intimidation

C. Five (5) Points

1. Loss of rein
2. Missing a diagonal for more than 2 strides
3. Use of either hand to instill fear or praise
4. Holding saddle with either hand
5. Blatant disobedience including kicking, pawing, bucking and rearing

D. Penalty score of zero (0)

1. Willful abuse of horse or schooling
2. Fall by horse or exhibitor
3. Illegal use of hands on reins
4. Use of prohibited equipment
5. Off pattern, including: knocking over or wrong side of cone or marker; never performing designated gait, lead or diagonal; over or under turning more than 1/4 turn.

Suggested English Control Patterns

475. Pattern A – Level I English Control

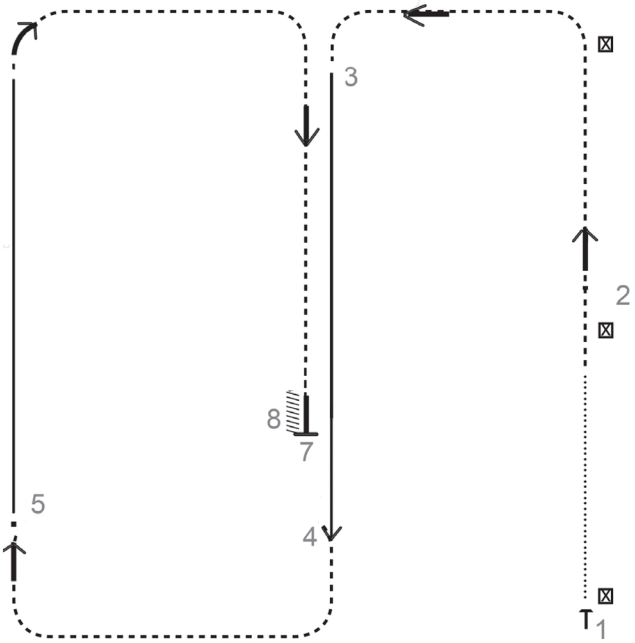

Walk: Canter: _____
Back: //////////////// Trot: - - - - -

1. Walk.
2. Trot on the right diagonal.
3. Canter down center on the left lead.
4. Sitting Trot.
5. Canter on the right lead.
6. Posting trot on the left diagonal down the center.
7. Halt.
8. Back three steps.

Leave arena on a loose rein at the free walk.

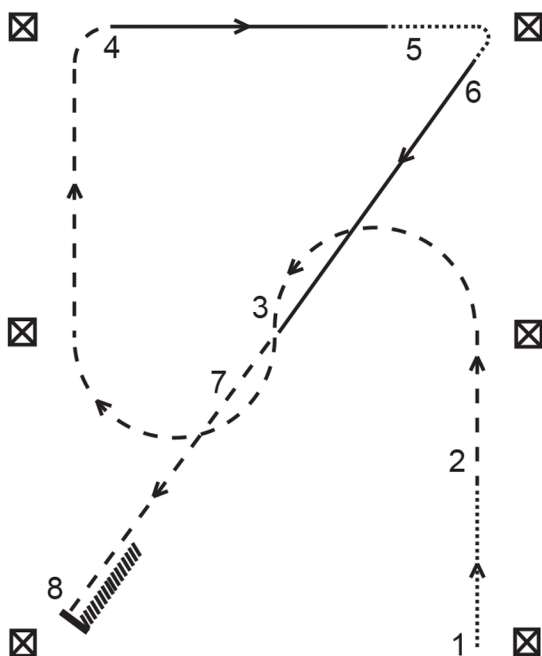

Walk: Canter: _____
 Back: // Trot: - - - - -

1. Normal walk.
2. Rising trot halfway between cones.
3. Serpentine showing change of diagonal.
4. Canter right lead $\frac{3}{4}$ of the way across.
5. Before corner, walk.
6. Canter left lead to the center.
7. Sitting trot.
8. Halt, back.

Leave arena on a loose rein at the free walk.

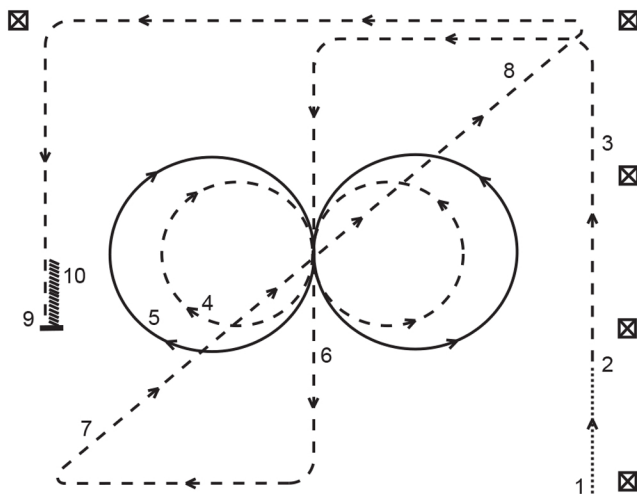

Walk: Canter: _____

Back: //////////////// Trot: - - - - -

1. Walk.
2. Sitting trot.
3. Working trot, rising.
4. Figure 8 at rising trot showing change of diagonal going to the right first.
5. Figure 8 at canter showing simple change of lead going to the right first.
6. Sitting trot.
7. Lengthened trot, rising demonstrating a change of diagonal while crossing center.
8. Working trot, sitting.
9. Halt.
10. Back.

Leave arena on a loose rein at the free walk.

Markers 30 feet to 50 feet apart. Suggested arena size 150 feet by 200 feet.

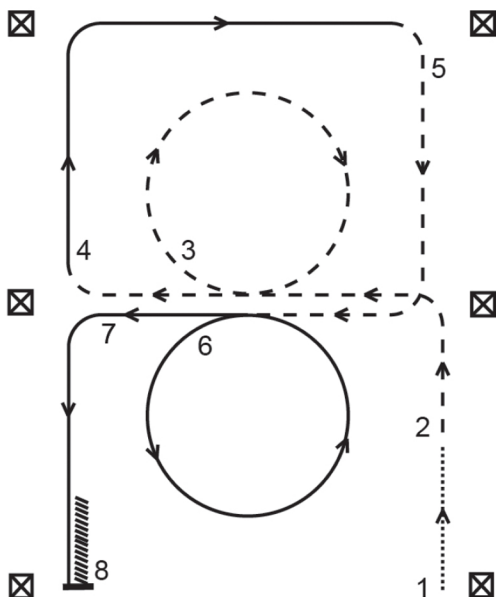

Walk: Canter: _____
 Back: //////////////// Trot: - - - - -

1. Normal walk.
2. Rising trot halfway between cones.
3. Change diagonals then circle right, rising trot.
4. Canter right lead.
5. Sitting trot.
6. Canter left lead, circle left.
7. Continue canter left lead.
8. Halt and back one horse length.

Leave arena on a loose rein at the free walk.

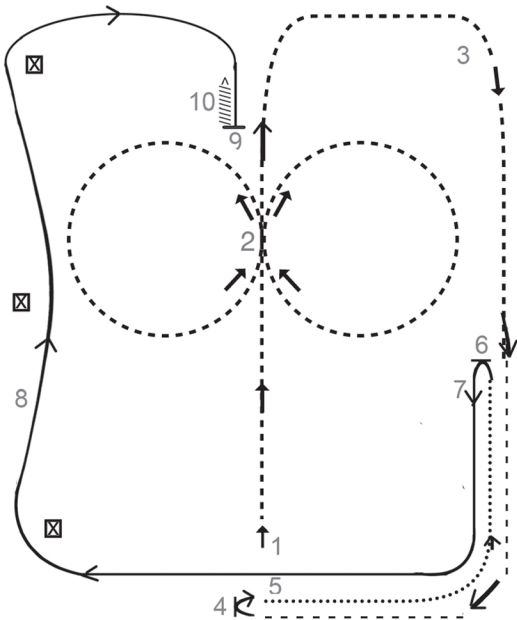

Walk: Canter: _____
 Back: //////////////// Trot: - - - - -

1. Sitting trot.
2. Rising trot, Figure 8 showing change of diagonals, starting to the right.
3. Extended trot, rising.
4. Halt, half turn (180 degrees) right on haunches.
5. Normal walk.
6. Halt, half turn (180 degrees) left on haunches.
7. Canter, right lead.
8. Two changes of leads through the cones, simple or flying.
9. Halt.
10. Back.

Leave arena on a loose rein at the free walk.

Markers 30 feet to 50 feet apart. Suggested arena size 150 feet by 200 feet.

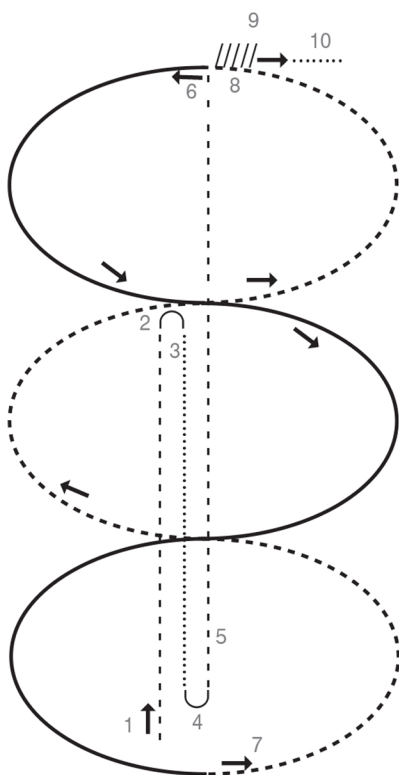

Walk: Canter: _____

Back: //////////////// Trot: - - - - -

1. Sitting trot.
2. Halt, half turn (180 degrees) right on haunches.
3. Normal walk.
4. Halt, half turn (180 degrees) left on haunches.
5. Lengthen trot rising.
6. Canter serpentine with appropriate changes of lead, simple or flying.
7. Rising trot serpentine with change of diagonals.
8. Halt.
9. Back.
10. Leave arena on a loose rein at the free walk.

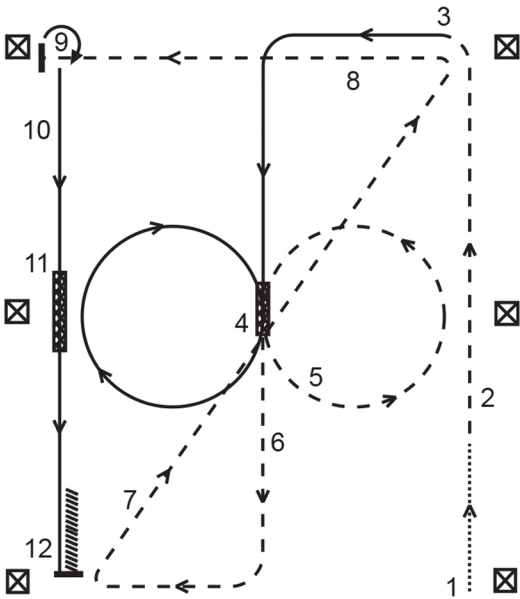

Walk: Canter: _____
 Back: /////////////// Trot: - - - - -
 Lead Changing Area: 

Lead changes may be simple or flying.

1. Normal walk.
2. Rising trot halfway between cones.
3. Canter left lead.
4. Change of lead, canter circle right lead.
5. Rising trot circle left.
6. Rising trot down center.
7. Extended trot across the diagonal, demonstrate a change of diagonal while crossing center.
8. Sitting trot.
9. Halt, 270° forehand turn right.
10. Canter left lead.
11. Change of lead, canter right lead.
12. Halt, back on horse length.

Leave arena on a loose rein at the free walk.

DRESSAGE

482. An individual score sheet shall be provided for each rider. A scribe shall be provided for the judge. Show management may elect to use United States Dressage Federation/United States Equestrian Federation tests as follows:

4-HLevelI–USDF/USEF Training Level Test I

4-HLevelII–USDF/USEF First Level Test I

4-HLevelIII–USDF/USEF Second Level Test I

4-HLevelIV–USDF/USEF Third Level Test I

For the latest version of tests, go to www.USEF.org.

483. The following scoring system will be used for all USDF/USEF tests:

SCORING:

10---- Excellent
9----- Very Good
8----- Good
7----- Fairly Good
6----- Satisfactory
5----- Sufficient
4----- Insufficient
3----- Fairly Bad
2----- Very Bad
0----- Not Executed

PENALTIES:

first error, 2 points;
second error, 4 points;
third error, elimination
(but, at discretion of judge, may continue the performance to the end unless the competitor's presence in the ring interferes with the start of 3 the next scheduled ride).

Note: At anytime willful abuse will not be tolerated and will result in elimination.

484. **Dressage test collective marks:**

TRAINING AND FIRST LEVEL

Gaits (freedom and regularity) x1

Impulsion (desire to move forward, elasticity of the steps, suppleness of the back, engagement of the hindquarters) x2

Submission (Attention and confidence, lightness and ease of movements, acceptance of the bridle, lightness of the forehand) x2

Rider's position and seat x1

Rider's correct and effective use of the aids x1

Harmony between rider and horse x1

SECOND AND THIRD LEVEL

Gaits (freedom and regularity) x1

Impulsion (desire to move forward, elasticity of the steps, suppleness of the back, engagement of the hindquarters) x2

Submission (Attention and confidence, lightness and ease of movements, acceptance of the bridle, lightness of the forehand, straightness) x2

Rider's position and seat x1

Rider's correct and effective use of the aids x1

Harmony between rider and horse x1

DRESSAGE ARENAS

Small Arena: 20m x 40m

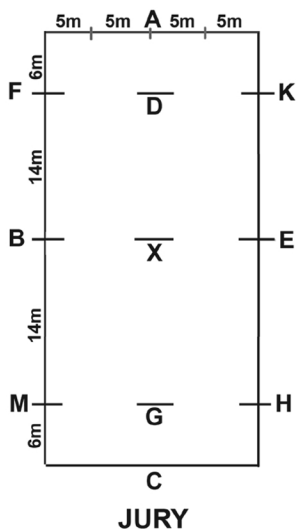

Large Arena: 20m x 60m

